208 Flynn Avenue, Suite 2A, Burlington, VT 05401 • Tel: 802-863-6225
85 Mechanic Street, Suite E2-3, Lebanon, NH 03766 • Tel: 603-442-9333
414 Union Street, Schenectady, NY 12305 • Tel: 518-205-9141

Bristol Subsurface Infiltration Chamber Design Project

School Street Site

100% Design Narrative

02/16/2022

Purpose

A stormwater master plan was developed for the Town of Bristol in 2019. Section 5 of this report included several proposed stormwater best management practices intended to reduce stormwater runoff and sediment discharge to the New Haven River, with a particular interest in reducing phosphorous discharge. The master plan included 30% concept designs for an underground chamber system on School Street.

The purpose of this project is to advance the 30% conceptual design documents to construction level documents for the Town of Bristol. Construction documents developed can then be used to secure funding for installation of the proposed School Street chamber system.

Contents

- Site Assessment & Preliminary Design
- Final Design
- Performance Report
- Permit Evaluation & Summary
- Opinion of Probable Cost
- Operation and Maintenance Manual

Attachments

1. School Street Site Performance Report
2. School Street Operation & Maintenance Manual
3. School Street Opinion of Probable Cost
4. School Street Site Construction Plan Set
5. School Street Site Civil Construction Specifications

Site Assessment & Preliminary System Designs

The following work has been completed:

A topographic site survey was conducted by Latitudes Land Surveying, LLC for the site locating existing features and visible utilities. This information was used to generate an existing conditions plan for use in stormwater design.

Existing Available Mapping available either online from the Vermont Center for Geographic Information or on the ANR Wastewater Permit database, was reviewed for the project site.

Soil Borings and Soil Infiltration Testing was performed by Randy Rhodes, PE of M&W Soils Engineering, Inc. This consisted of (2) borings to a depth of 12-feet below grade and a series of infiltration tests approximately 10-ft below existing grade. Material gradations were performed for samples retrieved at the 8-10-ft depth and 10-12-ft depth.

Results indicate clean gravel native material beginning approximately 1-ft below existing grade. There was no evidence of seasonal high water table, to depth of the borings.

Infiltration rates varied between testing locations. The lowest of the infiltration field rates has been used for the chamber system design. This rate of 9 inches per hour varies only slightly from the 6 inches per hour applied for the 30% design iteration.

Review of the 30% Design Information provided in the RFP was completed by our office once the existing conditions and soil investigation work concluded. Our review found areas where we believe the 30% design to be optimistic in terms of capacity and performance, but workable in concept. We also found underground infrastructure that would interfere with installation of the chamber system as outlined in the 30% plans.

The roughly 30-ac drainage area for the site, consisting primarily of the residential neighborhood to the northwest, remains unchanged from the 30% design iteration.

Final Design

The final design is comprised of (81) Stormtech MC-4500 chambers arranged in (3) rows, details are provided in the attached plan set. This is similar to what was shown on the 30% plans but expanded by (13) chambers and reconfigured to include bypass and inlet tanks and to minimize impacts to nearby specimen trees.

The chamber system has been sized to infiltrate the 1-inch water quality storm. A diversion structure upstream of the treatment area will bypass larger storm events. An inlet tank with an internal baffle is proposed to prevent sediment from entering the chamber system.

Although 50% pretreatment is required per the Vermont Stormwater Management Manual, that volume would require a significant increase in the treatment area footprint due to the large size of the contributing drainage area. This would require more space than is available.

It is likely that some amount of pretreatment is provided upstream by the existing stormwater conveyance system and sheet flow over vegetated areas. The proposed system does provide pretreatment by the inlet tank described above, along with an isolator row which adds a layer of geotextile fabric below the chambers to prevent any suspended sediments from migrating into the filtering stone layer below.

The orientation of this systems is largely based on the desire to preserve portions of the School Street right of way for future buried utility lines. Installation of this system will require deep excavations, and in order to minimize impact to the existing park features a temporary sheet pile wall, or other means of temporary shoring will be required during construction.

An existing municipal water line runs below School Street within the proposed project area and is estimated to be nearly 100-years old. It is recommended that this waterline be relocated concurrent with the chamber system installation. Excavation near a water line of that age risks damage to the water line itself and raises the level of risk to the excavation crew unless that portion can be deactivated during adjacent excavation work.

System Performance Report – STP Calculator

The system performance report estimates 16.19 kg/year phosphorus loading reduction. See the full report (attached) for details.

Permit Evaluation & Summary

No state permits are anticipated as being required as part of this project. Earth disturbance will be below the 1-acre threshold for which a Stormwater Construction General Permit is required. No expansion or substantial redevelopment of impervious surface is proposed; therefore an operational stormwater permit is not required. The ANR DEC Stormwater and Rivers Departments were contacted to review the proposed projects. Both agencies declined to provide comment given the non-jurisdictional nature of the project.

Opinion of Probable Cost

An opinion of probable cost has been developed for the final design and is based on the Vermont Agency of Transportation 2-year average price list from January 2018-January 2020, available bid pricing from similar projects, and budget estimates provided by both CAMP Precast and ADS Stormtech. Details are provided in the attached Opinion of Probable Cost. Final prices would be determined by direct quotes from a general contractor and are subject to change based on market rates, availability and distribution.

Operation and Maintenance Manual

In general, the system should be inspected twice a year, once after snow-melt, once before leaf-drop and after rainfall events of at least 2.5-inches in a 24-hour period. Structured pretreatment devices should be cleaned annually with a vac truck to remove collected sediments. The chamber system should also be cleared of sediment accumulation reaches a depth of 6-inches at the isolator row inlet. A detailed Operation & Maintenance Manual is included as an attachment to this report.

Stormwater Treatment Practice Calculator

Identification

Date	12/28/2021
WPD ID	
STP Name	

Loading Information

Drainage Area	4 - Otter Creek	
Impervious Area	10.262	acres
Pervious Area	21.858	acres

STP Information

STP Type	Subsurface Infiltration	
Storage Volume	15776	ft ³
Infiltration Rate	8.27 (Sand, HSG - A)	in/hr
Filter Course Depth		in

Estimated Phosphorus Reduction

Load	18.18	kg/year
STP Capacity	0.35	in
Efficiency	89.05	%
Reduction	16.19	kg/year

Stormwater Operation & Maintenance Manual

SCHOOL STREET SUBSURFACE INFILTRATION CHAMBER SYSTEM

This project features stormwater appurtenances which require inspection and maintenance on a regular basis.

These features include:

- (2) underground tanks (bypass tank & inlet tank)
- (1) underground infiltration chamber systems

The Town of Bristol shall be responsible for providing ongoing site inspections and maintenance to provide long-term functionality of the stormwater system. It is recommended that, at minimum, the site be inspected on a semi-annual basis, once after snow-melt and once before leaf-drop.

This document identifies the inspection and maintenance requirements of each of the stormwater features.

1. The owner shall be responsible for conducting the required inspection, reporting and maintenance activities outlined by this document:

Town of Bristol
1 South Street, PO Box 249
Bristol, VT 05443

2. An inspection checklist (attached) shall be completed during each inspection.
3. An Operation & Maintenance Log shall be completed to track each inspection as well as maintenance activities. The Log can be found attached to this document.
4. An Operation & Maintenance Plan identifies on-site stormwater appurtenances and is attached to this document.
5. The frequency of the inspections and maintenance requirements shall be as follows:

Systems shall be inspected in the spring and fall and also following storm events exceeding 2.5-inches of rainfall in a 24-hour period, with maintenance and rehabilitation conducted as warranted by such inspection.

UPT – Underground Pretreatment Tanks or Forebays:

- Systems shall be inspected twice annually
- Structures shall be cleaned annually (by use of vacuum truck or “clam-shell”) and when inspection indicates sediment accumulation is approaching a depth of 3 to 6-inches.
- All floating debris shall be removed and disposed of in an acceptable manner.
- Remove floating hydrocarbons immediately whenever detected by inspection.

UIC – Underground Infiltration Chambers:

- During the first growing season, bi-weekly inspections shall be conducted to assess vegetation health until the vegetation is established.
- Systems shall be inspected after the initial two storm events to ensure proper function and that no erosion or sour is occurring.
- Systems shall be inspected at twice annually, and following storm events exceeding 2.5-inches of rainfall in a 24-hour period, with maintenance and rehabilitation conducted as warranted by such inspection.
- Vegetation health, density and diversity shall be conducted at least twice annually during both the growing and non-growing season.
- Isolator Row shall be cleaned when inspection indicates sediment accumulation is approaching a depth of 6-inches at the inlet.
- Infiltration area shall not be used as snow storage during the winter months. Disposal of sediments and other wastes shall be in conformance with applicable local, state and federal laws.

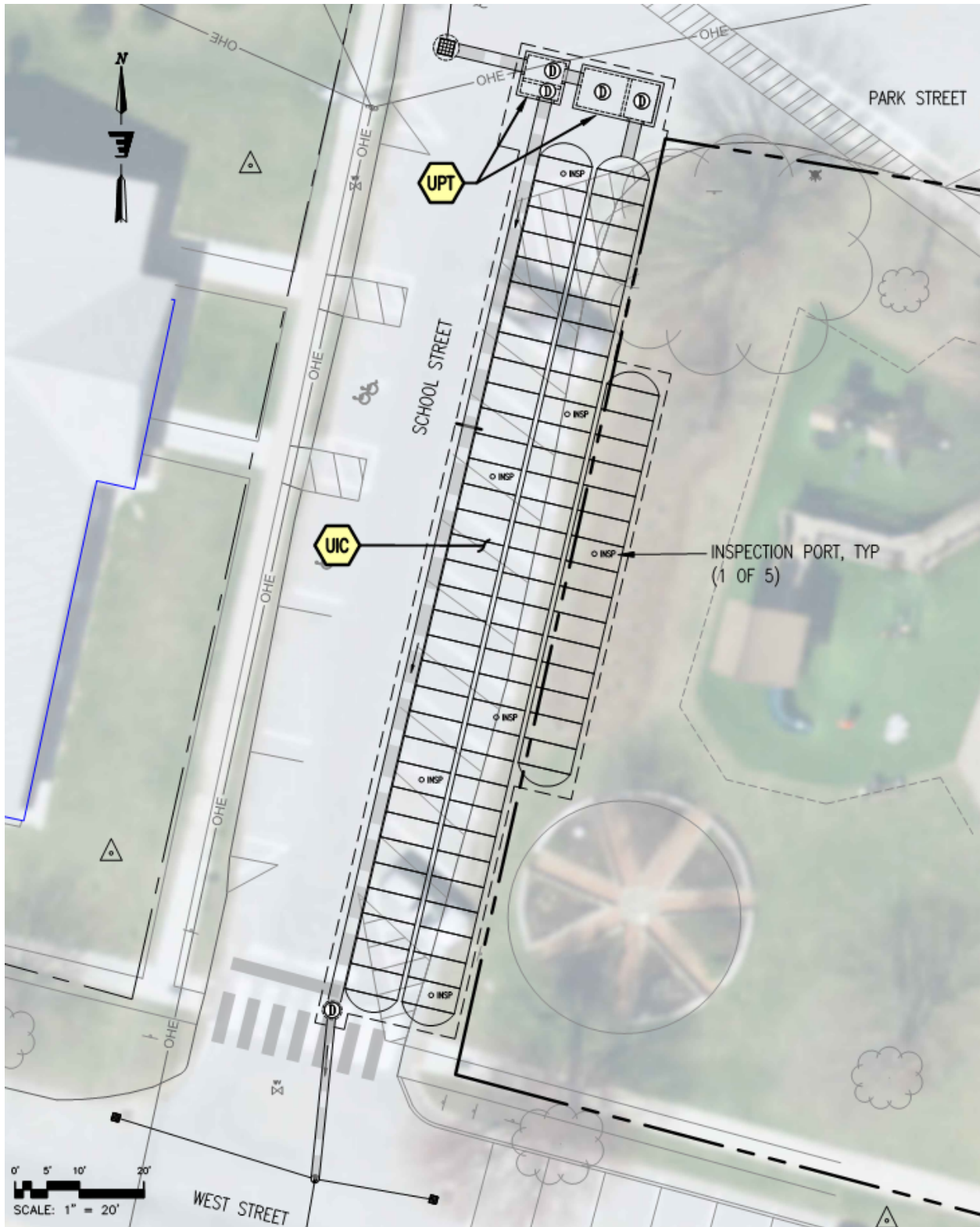

O&M Checklist (continued)

Inspector:	Date:
Current Weather:	Time:
Rainfall in the Last 24 Hours (in): Can be checked here: http://www.nrcc.cornell.edu/page_nowdata.html	

Underground Pretreatment Tanks: Inspection Required Twice Annually. Cleaning Required Annually.
 ***Inspections Required after rainfall events of at least 1-inch during six months after installation

Items Inspected (Frequency)	Checked		Maintenance Needed		Maintenance Performed	
	Y	N	Y	N	Y	N
DEBRIS CLEANOUT						
1. Contributing areas clean of debris.						
2. Litter (trash, debris, etc.) have been removed						
SEDIMENTATION TANK						
3. All Floating debris removed and disposed of.						
4. Sediment removed when accumulation approaches a depth of 3 to 6-inches.						
5. Tank cleaned out at least once annually.						
6. Floating hydrocarbons removed immediately.						
INLET / OUTLET STRUCTURES						
7. Good condition, no need for repair						
8. No evidence of sediment build-up.						
9. No evidence of any blockages.						

O&M Checklist (continued)

Inspector:	Date:
Current Weather:	Time:
Rainfall in the Last 24 Hours (in): Can be checked here: http://www.nrcc.cornell.edu/page_nowdata.html	

Underground Infiltration Chamber System Components: Inspection Required Twice Annually

***Inspection Required after at least two initial storm events to ensure proper drainage

***Inspections Required Bi-weekly during first growing season to ensure vegetation health

***Inspections Required after rainfall events of at least 2.5-inches in a 24-hour period

Items Inspected (Frequency)	Checked		Maintenance Needed		Maintenance Performed	
	Y	N	Y	N	Y	N
DEBRIS CLEANOUT						
1. Infiltration areas and contributing areas clean of debris						
2. No dumping of yard wastes into infiltration area						
3. Litter (trash, debris, etc.) have been removed						
VEGETATION (where applicable)						
4. No evidence of erosion.						
5. Vegetative density exceeds a 90% cover.						
6. No evidence of invasive species or woody vegetation.						
DEWATERING AND SEDIMENTATION						
7. Infiltration system dewateres within 72 hours of storms.						
8. No evidence of standing water.						
9. No evidence of accumulated sediment.						
10. Sediment removed from the isolator row when accumulation approaches a depth of 6-inches at the inlet.						
OUTLETS/OVERFLOW						
11. Good condition, no need for repair.						
12. No evidence of sedimentation build-up.						
13. No evidence of any blockages.						

208 Flynn Avenue, Suite 2A, Burlington, VT 05401 • Tel: 802-863-6225 • Fax: 802-863-6306

O&M Log

Date	Appurtenances Inspected	Maintenance Performed	Inspector's Signature

Opinion of Probable Cost for:
 School Street Subsurface Stormwater Infiltration System
 Bristol, Vermont



Civil Site Work

Date: February 2022

By: HKW/PB

Item	Quantity	Unit Price	Total
Erosion Prevention & Sediment Control Allowance	Lump Sum	\$ 5,000.00	\$ 5,000
Traffic Control & Barrier Allowance	Lump Sum	\$ 5,000.00	\$ 5,000
Site Demolition & Preparation			
Tree Removal	1 EA	\$ 1,550.00 EA	\$ 1,550
Saw Cut Pavement	101 LF	\$ 5.00 /LF	\$ 505
Temporary Sheet Piling	160 LF	\$ 150.00 /LF	\$ 24,000
Equipment for Driving Piling	Lump Sum	\$ 48,700.00	\$ 48,700
Excavation: Existing Pavement & Concrete, assumed 4" depth	81 CY	\$ 32.00 /CY	\$ 2,607
Excavation: Existing Surface Treatment Subbase, assumed 8" depth	163 CY	\$ 20.00 /CY	\$ 3,259
Excavation: Existing Subgrade Material for Chamber System, 9' depth	1,333 CY	\$ 20.00 /CY	\$ 26,667
Disposal of Existing Subgrade Material	1,333 CY	\$ 22.00 /CY	\$ 29,333
Sign Removal	3 EA	\$ 10.67 EA	\$ 32
Storm Line Removal	150 FT	\$ 5.00 /LF	\$ 750
Exploratory Test Pit Excavation, assumed 5-ft depth at (2) locations	5 CY	\$ 26.00 /CY	\$ 120
		Site Demolition Subtotal	\$ 137,524

Stormwater System Components			
6-FT ID Precast Reinforced Concrete Structure with frame & grate	1 EA	\$ 3,650.00 EA	\$ 3,650
4-FT ID Precast Reinforced Concrete Structure with frame & cover	1 EA	\$ 2,450.00 EA	\$ 2,450
7ft x 7xft Heavy Duty Precast Concrete Square Structure with Internal Weir & (2) Frames with Solid Covers (Bypass Structure)	1 EA	\$ 8,950.00 EA	\$ 8,950
6ft x 12ft Heavy Duty Precast Concrete Tank with Internal Weir & (2) Frames with Solid Covers (Inlet Tank)	1 EA	\$ 9,260.00 EA	\$ 9,260
24-inch HDPE Storm Pipe - Bypass Line & Chamber System Inlet	150 LF	\$ 88.00 /LF	\$ 13,200
24-inch PVC Storm Pipe - Bypass Structure Inlet and Outlet Piping	15 LF	\$ 88.00 /LF	\$ 1,320
Chamber System Components			
MC4500 Stormtech Chamber Units	81 EA	\$ 982.00 EA	\$ 79,542
MC4500 Stormtech Chamber Plain End Caps	4 EA	\$ 1,025.00 EA	\$ 4,100
MC4500 Stormtech Chamber End Caps with Bottom Outlet	2 EA	\$ 1,200.00 EA	\$ 2,400
Chamber Stone (plus 10% for pipe and tanks)	704 CY	\$ 50.00 /CY	\$ 35,210
6" Inspection Port	7 EA	\$ 155.00 EA	\$ 1,085
Mirafi 180N, Filter Fabric Blanket Surrounding Chamber Stone	910 SY	\$ 1.50 /SY	\$ 1,365
Woven Geotextile for Isolator Row	316 SY	\$ 1.00 /SY	\$ 316
Stormwater System Installation Equipment and Labor	12 DAYS	\$ 4,000.00 /DAY	\$ 48,000
		Stormwater System Subtotal	\$ 210,848

Pavement Replacement			
12" Coarse Crushed Gravel Pavement Subbase	249 CY	\$ 42.00 /CY	\$ 10,453
6" Fine Crushed Gravel Pavement Subbase	124 CY	\$ 43.00 /CY	\$ 5,351
Geotextile for Pavement Subgrade (outside limits of chamber system)	429 SY	\$ 1.50 /SY	\$ 643
1.5" Bituminous Concrete Pavement Base Course, Type III	61 TONS	\$ 175.00 /TON	\$ 10,658
2.5" Bituminous Concrete Pavement Wearing Course, Type II	102 TONS	\$ 175.00 /TON	\$ 17,763
Emulsified Asphalt	25 CWT	\$ 22.00 /CWT	\$ 546
Sidewalk Replacement			
12" Coarse Crushed Gravel Sidewalk Subbase	2 CY	\$ 42.00 /CY	\$ 78
6" Fine Crushed Gravel Sidewalk Subbase	1 CY	\$ 43.00 /CY	\$ 43
Class B Concrete	6 SY	\$ 72.00 /SY	\$ 432

continued on next page

Miscellaneous Site Work

Erecting Salvaged Signs	3 EA	\$	30.00 EA	\$	90
4-inch White Line Striping	500 LF	\$	0.83 /LF	\$	415
24-inch Stop Bar	15 LF	\$	4.00 /LF	\$	60
Crosswalk Marking	32 LF	\$	18.00 /LF	\$	576
Handicap Parking Symbol	2 EA	\$	95.00 EA	\$	190
			Site Work Subtotal	\$	47,298

Project Subtotal	\$	405,670
10% Contingency	\$	40,567
15% Overhead	\$	60,850
Total Project Construction Cost	\$	507,087

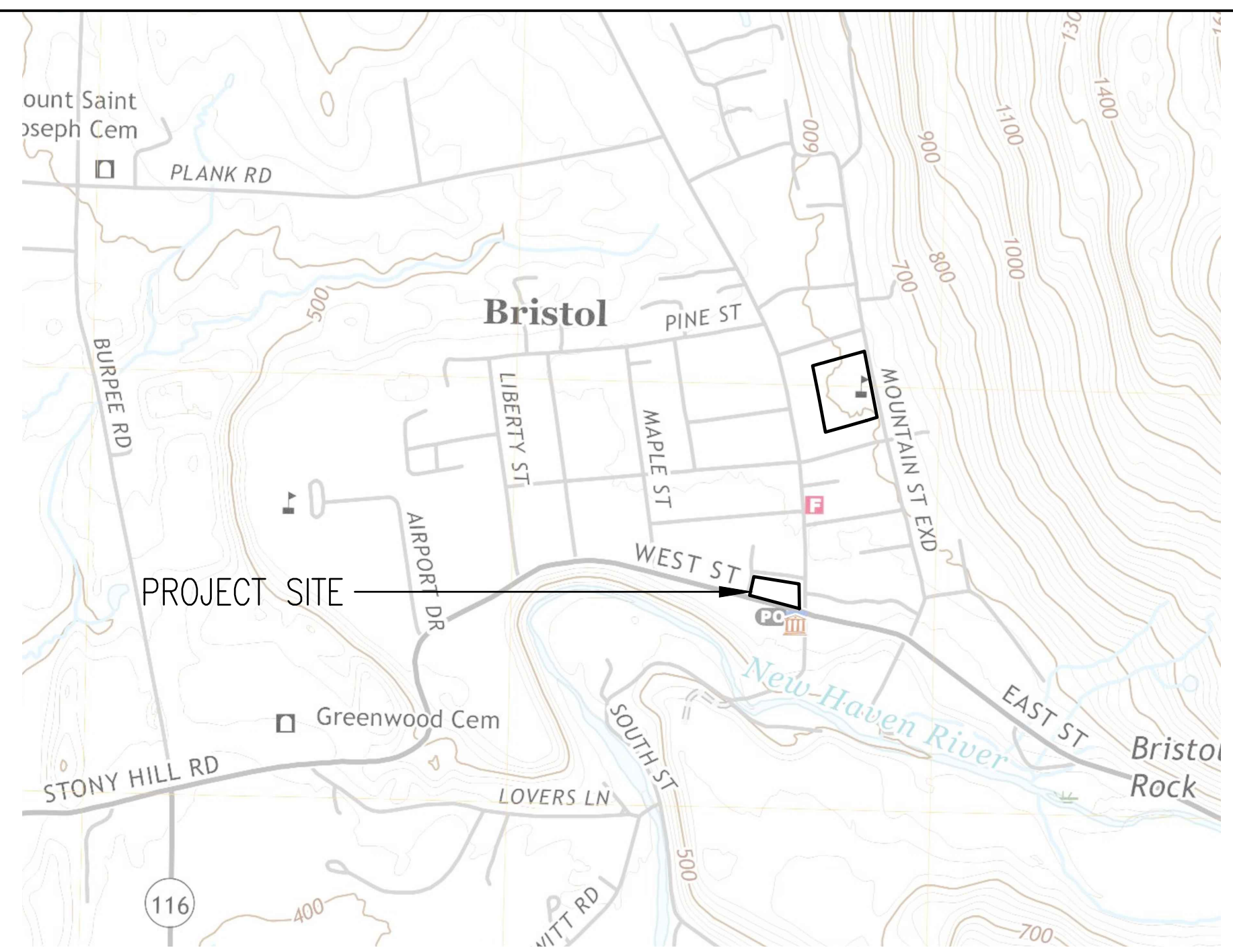

LOCATION MAP
SCALE: 1" = 1,000'

EXISTING CONDITIONS LEGEND

- APPROXIMATE PROPERTY LINE
- - - 769 1-FT CONTOUR INTERVAL
- - - 770 5-FT CONTOUR INTERVAL
- EDGE OF PAVEMENT/CURB
- APPROXIMATE LINE STRIPING
- SD [Symbol] STORMLINE/CATCH BASIN/DRAINAGE MANHOLE
- S [Symbol] SEWERLINE/SANITARY MANHOLE
- W [Symbol] WATERLINE/VALVE/HYDRANT
- OHE [Symbol] OVERHEAD POWERLINE/POWERTPOLE/LIGHTPOLE
- [Symbol] EXISTING TREE
- [Symbol] EXISTING SIGN
- B1 [Symbol] SOIL BORING LOCATION

SURVEY NOTES

1. EXISTING PHYSICAL FEATURES AND TOPOGRAPHY SHOWN HERE HAS BEEN TAKEN FROM A SURVEY PERFORMED BY LATITUDES LAND SURVEYING, LLC IN JUNE/JULY OF 2021.
2. PROPERTY LINES ARE BASED ON INFORMATION PROVIDED BY VERMONT CENTER FOR GEOGRAPHIC INFORMATION AND ARE APPROXIMATE ONLY.
3. UTILITIES SHOWN DO NOT PURPORT TO CONSTITUTE OR REPRESENT ALL UTILITIES LOCATED UPON OR ADJACENT TO THE SURVEYED PREMISES.
4. NORTH ORIENTATION IS REFERENCED TO APPROXIMATE VERMONT GRID NORTH DERIVED FROM GPS READINGS OBSERVED BY OTHERS.
5. ELEVATIONS ARE REFERENCED TO APPROXIMATE NAVD 88 DERIVED FROM GPS READINGS OBSERVED BY OTHERS.
6. EXISTING UTILITIES SHOWN ON PLANS WERE TAKEN FROM FIELD OBSERVATIONS OF VISIBLE UTILITIES AND PAINTED MARKINGS. CONTRACTOR SHALL BE RESPONSIBLE FOR FIELD VERIFYING UTILITY LOCATIONS PRIOR TO COMMENCING WORK AND NOTIFYING THE ENGINEER OF ANY DISCREPANCY BETWEEN UTILITIES AS SHOWN AND AS FOUND. THE CONTRACTOR SHALL CONTACT DIG SAFE (811 or 888-344-7233) A MINIMUM OF 72 HOURS, BUT NOT INCLUDING SATURDAYS, SUNDAYS AND LEGAL HOLIDAYS, PRIOR TO ANY CONSTRUCTION.

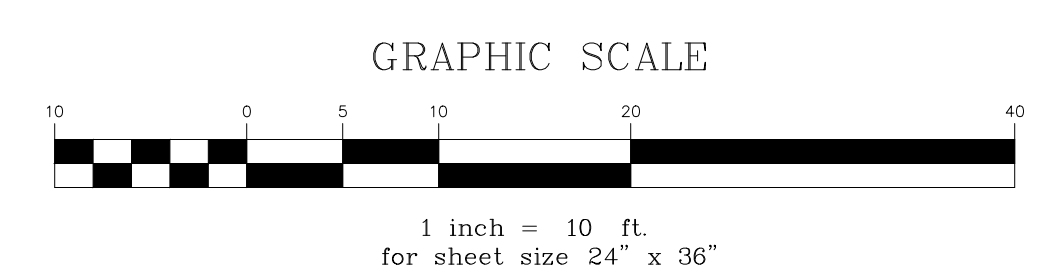

No.	Description	Date	Stamp

ENGINEERING VENTURES PC
 208 Pym Avenue, Suite 2A, Burlington, VT 05401 s 802-883-6225
 885 Mechanic Street, Suite E2-3, Lebanon, NH 03766 s 603-442-9333
 414 Union Street, Schenectady, NY 12305 s 518-630-9614
 www.engineeringventures.com

Town of Bristol
 c/o Valerie Caples, Town Administrator
 1 South Street, PO Box 249
 Bristol, Vermont 05443
 802-453-2410 ext. 1

Existing Conditions Plan
 School Street Site
 Subsurface Infiltration Chamber Project
 Town of Bristol, Addison County, Vermont

Sheet Title:	EV Project #	21230
Drawn By:	Drawn By:	HKW
Checked By:	Checked By:	PB
Scale:	Scale:	1" = 10'
Date:	Date:	02/10/2022

C1.0

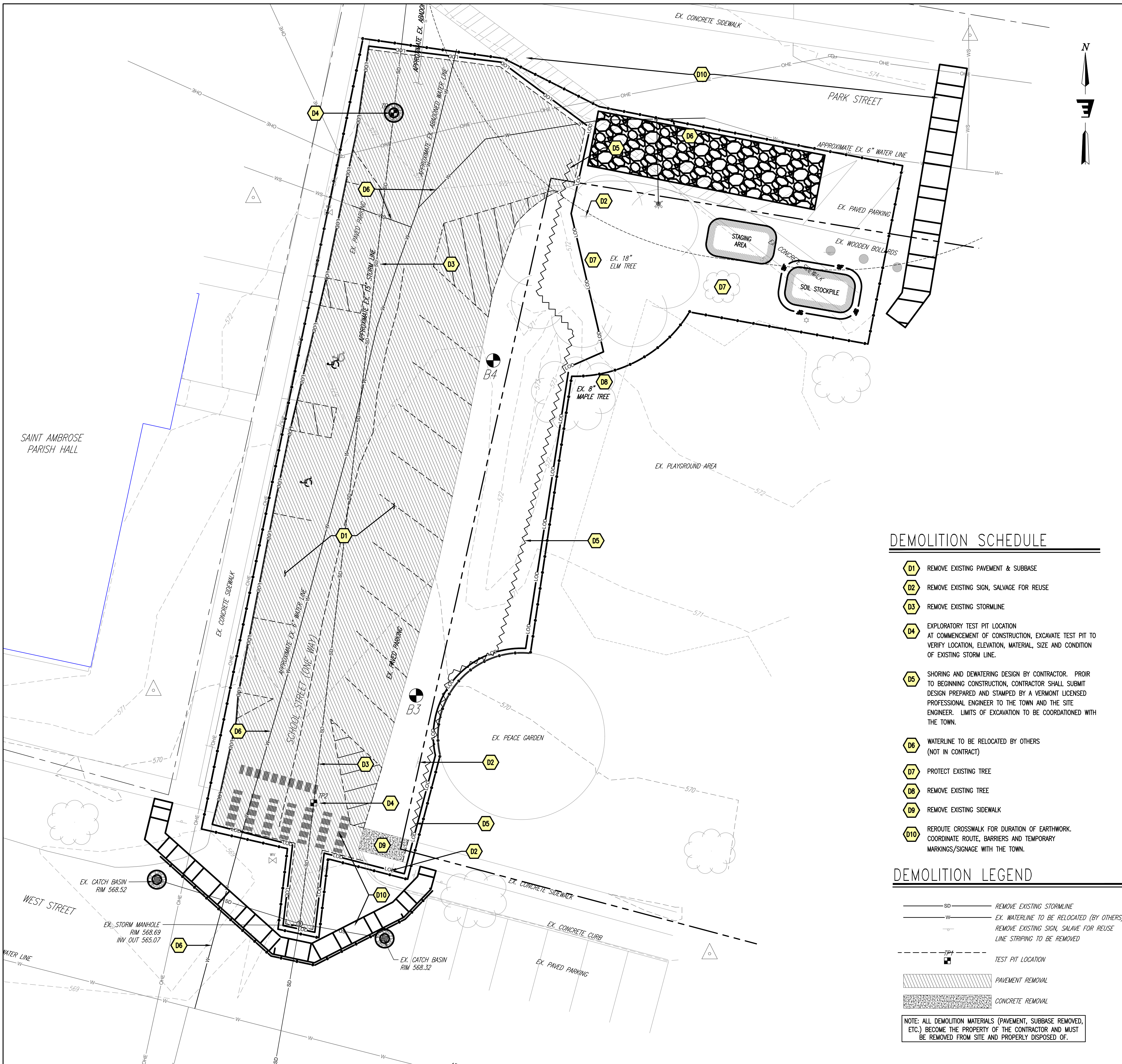

EROSION CONTROL LEGEND

REFER TO NOTES AND DETAILS ON SHEET C3.2

- TEMPORARY INLET PROTECTION** - INSTALL AS INDICATED ON PLANS. MANUFACTURED FABRIC INLET PROTECTION INSTALLED PER MANUFACTURER REQUIREMENTS OR FIBER ROLL WRAPPED AROUND RIM AND STAKED TO PREVENT BYPASSING.
- TEMPORARY STABILIZED CONSTRUCTION ENTRANCE** THIS STRUCTURAL MEASURE IS A STABILIZED PAD OF AGGREGATE UNDERLAIN WITH FILTER FABRIC LOCATED AT ANY POINT WHERE TRAFFIC WILL BE ENTERING OR LEAVING A CONSTRUCTION SITE TO OR FROM A PUBLIC RIGHT-OF-WAY, STREET, ALLEY, SIDEWALK, OR PARKING AREA. THE PURPOSE OF A STABILIZED CONSTRUCTION ENTRANCE IS TO REDUCE OR ELIMINATE THE TRACKING OF SEDIMENT ONTO PUBLIC RIGHTS-OF-WAY OR STREETS. THIS WILL REMAIN IN PLACE AND BE MAINTAINED UNTIL THE PROJECT SITE HAS BEEN PERMANENTLY STABILIZED. ONCE REMOVED, THE IMPACTED AREA SHALL BE SEEDED AND MULCHED.
- TEMPORARY STAGING AND WASTE AREAS (APPROXIMATE)** THESE ARE APPROVED LOCATIONS WHERE NON-SOIL, NON-ERODIBLE MATERIALS MAY BE STORED. SOILS SHALL NOT BE STORED IN THESE AREAS.
- TEMPORARY SOIL STOCKPILE AREAS (APPROXIMATE)** THESE ARE APPROVED LOCATIONS WHERE TOPSOIL AND OTHER SOIL MATERIALS MAY BE STORED. THESE STOCKPILES WILL BE PROTECTED FROM EROSION BY A NUMBER OF METHODS, INCLUDING INSTALLING SILT FENCING AROUND THE DOWN GRADIENT PERIMETER OF THE STOCKPILE AND SEEDING AND MULCHING THE STOCKPILE WHEN NOT IN USE FOR MORE THAN FIVE DAYS. FIRMLY ANCHORED TARPS MAY BE USED IN PLACE OF MULCH.
- CHAIN LINK (c) CONSTRUCTION LIMIT FENCING** THIS STRUCTURAL MEASURE IS INSTALLED ALONG THE PERIMETER OF THE PROJECT AREA. IN MANY CASES THE LIMIT OF CONSTRUCTION WILL COINCIDE WITH THE FENCING OR INDICATE BUFFER AREAS TO BE PROTECTED. THE FENCING IS EFFECTIVE WHEN USED TO SEPARATE THE PROJECT AREA FROM ADJACENT AREAS USED BY THE PUBLIC. THESE WILL REMAIN IN PLACE AND BE MAINTAINED UNTIL THE PROJECT SITE HAS BEEN PERMANENTLY STABILIZED. CONFIRM LOCATION, EXTENTS AND GATES WITH OWNER. FENCE LOCATION AND GATES TO BE RE-ADJUSTED AS NECESSARY BASED ON OWNER REQUIREMENTS AND COORDINATION.
- TEMPORARY SILT FENCING OR STRAW WATTLES** THIS STRUCTURAL MEASURE IS A TEMPORARY BARRIER OF GEOTEXTILE FABRIC OR FIBER ROLL USED TO INTERCEPT SEDIMENT LADEN RUNOFF FROM SMALL DRAINAGE AREAS OF DISTURBED SOIL. IT IS INSTALLED ALONG THE PERIMETER OF IMPACTED AREAS AND ALONG THE BASE OF THE FILL SLOPES. ADDITIONALLY, WHEN DESIGNATED ALONG THE LIMITS OF DISTURBANCE, INSTALL CONSTRUCTION FENCE BEHIND THE SILT FENCE. SILT FENCING IS EFFECTIVE IN REDUCING STORMWATER RUNOFF VELOCITIES, ASSIST IN THE DEPOSITION OF TRANSPORTED SEDIMENT LOAD AND PREVENT EROSION OF SOILS ONTO ADJACENT AREAS. THESE WILL REMAIN IN PLACE AND BE MAINTAINED UNTIL THE PROJECT SITE HAS BEEN PERMANENTLY STABILIZED.
- LIMITS OF DISTURBANCE** THE CONTRACTOR SHALL CONTAIN ANY EARTH MOVING ACTIVITIES WITHIN THE DESIGNATED LIMITS SHOWN ON THIS PLAN. THE ENGINEER SHALL REVIEW THE SITE TO MAKE ANY ADJUSTMENTS TO ACCOUNT FOR ENVIRONMENTALLY SENSITIVE AREAS, SPECIMEN TREES AND SPECIAL AREAS OF CONCERN.

DEMOLITION SCHEDULE

- D1** REMOVE EXISTING PAVEMENT & SUBBASE
- D2** REMOVE EXISTING SIGN, SALVAGE FOR REUSE
- D3** REMOVE EXISTING STORMLINE
- D4** EXPLORATORY TEST PIT LOCATION AT COMMENCEMENT OF CONSTRUCTION, EXCAVATE TEST PIT TO VERIFY LOCATION, ELEVATION, MATERIAL, SIZE AND CONDITION OF EXISTING STORM LINE.
- D5** SHORING AND DEWATERING DESIGN BY CONTRACTOR. PRIOR TO BEGINNING CONSTRUCTION, CONTRACTOR SHALL SUBMIT DESIGN PREPARED AND STAMPED BY A VERMONT LICENSED PROFESSIONAL ENGINEER TO THE TOWN AND THE SITE ENGINEER. LIMITS OF EXCAVATION TO BE COORDINATED WITH THE TOWN.
- D6** WATERLINE TO BE RELOCATED BY OTHERS (NOT IN CONTRACT)
- D7** PROTECT EXISTING TREE
- D8** REMOVE EXISTING TREE
- D9** REMOVE EXISTING SIDEWALK
- D10** REROUTE CROSSWALK FOR DURATION OF EARTHWORK. COORDINATE ROUTE, BARRIERS AND TEMPORARY MARKINGS/SIGNAGE WITH THE TOWN.

GENERAL NOTES

1. EXACT OBJECT LOCATIONS MAY DIFFER FROM THAT AS SHOWN, AND ADDITIONAL SUB-SURFACE AND SURFACE UTILITIES AND STRUCTURES MAY EXIST. THE CONTRACTOR IS TO PROCEED WITH CARE IN EXECUTING ANY WORK AND TO CALL DIG SAFE 72 HOURS PRIOR TO ANY DIGGING, DRILLING OR BLASTING.
2. THE ENGINEER SHALL BE NOTIFIED IN WRITING OF ANY CONDITIONS THAT VARY FROM THOSE SHOWN ON THE PLANS. THE CONTRACTOR'S WORK SHALL NOT VARY FROM THE PLANS WITHOUT THE EXPRESSED APPROVAL FROM THE ENGINEER AND PROJECT MANAGER (OWNER).
3. THE CONTRACTOR IS INSTRUCTED TO COOPERATE WITH ANY AND ALL OTHER CONTRACTORS PERFORMING WORK ON THIS JOB SITE DURING THE PERFORMANCE OF THIS CONTRACT.
4. THE CONTRACTOR SHALL RESTORE LAWNS, DRIVEWAYS, CULVERTS, SIGNS AND OTHER PUBLIC OR PRIVATE PROPERTY DAMAGED OR REMOVED TO EXISTING CONDITIONS OR BETTER AS DETERMINED BY THE ENGINEER. ANY DAMAGED TREES, SHRUBS AND/OR HEDGES SHALL BE REPLACED AT THE CONTRACTOR'S EXPENSE, UNLESS NOTED OTHERWISE.
5. THE CONTRACTOR WILL PROTECT EXISTING PROPERTY LINE MONUMENTATION. ANY MONUMENTATION DISTURBED OR DESTROYED, AS JUDGED BY THE ENGINEER OR OWNER SHALL BE REPLACED AT THE CONTRACTOR'S EXPENSE UNDER THE SUPERVISION OF A VERMONT STATE LICENSED LAND SURVEYOR.
6. IT IS THE CONTRACTOR'S RESPONSIBILITY TO EXAMINE ALL PLAN SHEETS AND SPECIFICATIONS, AND COORDINATE WORK WITH ALL CONTRACTS FOR THE SITE.
7. IT IS THE CONTRACTOR'S RESPONSIBILITY TO CONDUCT EXPLORATORY TEST PITS AS MAY BE REQUIRED TO DETERMINE UNDERGROUND CONDITIONS.
8. ALL TRENCH EXCAVATION AND ANY REQUIRED SHEETING AND SHORING SHALL BE DONE IN ACCORDANCE WITH THE LATEST OSHA REGULATIONS FOR CONSTRUCTION. TEMPORARY SHORING WHERE NEEDED TO PREVENT DAMAGE TO EXISTING SITE FEATURE NOT SLATED FOR REMOVAL IS THE RESPONSIBILITY OF THE CONTRACTOR.
9. CONTRACTOR SHALL BE RESPONSIBLE FOR DEWATERING AND THE MAINTENANCE OF SURFACE DRAINAGE DURING THE COURSE OF WORK.
10. MAINTAIN FLOW FOR ALL EXISTING UTILITIES, UNLESS NOTED OTHERWISE.
11. ALL SITE FILL SHALL MEET SELECTED FILL STANDARDS UNLESS NOTED OTHERWISE ON THE DRAWINGS.
12. CONTRACTOR TO GRADE ALL AREAS ON THE SITE TO PROVIDE POSITIVE DRAINAGE AWAY FROM BUILDINGS AND IMPERVIOUS SURFACES.
13. THE CONTRACTOR SHALL BE RESPONSIBLE FOR PROVIDING ALL FIELD LAYOUT. THE CONTRACTOR SHALL PROVIDE MARKED-UP AS-BUILT PLANS WITH TIES AND DIMENSIONS FOR ALL UTILITIES SHOWING CONNECTIONS, BENDS, VALVES, LENGTHS OF LINES AND INVERTS. AS-BUILT PLANS SHALL BE REVIEWED BY THE OWNER AND HIS REPRESENTATIVES BEFORE UTILITIES WILL BE ACCEPTED.
14. CONTRACTOR SHALL BE RESPONSIBLE FOR PROPER INSTALLATION, MONITORING, MAINTENANCE AND REMOVAL OF ALL TEMPORARY EROSION CONTROL MEASURES AND TAKING PRECAUTIONARY STEPS TO AVOID ANY SEDIMENT TRANSFER TO NEIGHBORING SITES OR WATERS OF THE STATE. THIS INCLUDES DUST CONTROL AND SWEEPING TO REMOVE TRACKED SEDIMENT FROM PAVED AREAS ADJACENT TO THE WORK AREA AT THE END OF EACH WORK DAY.
15. IT IS THE CONTRACTOR'S RESPONSIBILITY TO MAINTAIN A CLEAN WORK SITE. THE CONTRACTOR SHALL REVIEW THE SITE AT THE END OF EACH WORK DAY AND PERFORM TASKS AS NECESSARY TO MAINTAIN THE CLEANLINESS OF THE SITE.
16. THE CONTRACTOR SHALL WORK IN ACCORDANCE WITH VOSHA REGULATIONS.

DEMOLITION LEGEND

- REMOVE EXISTING STORMLINE
- EX. WATERLINE TO BE RELOCATED (BY OTHERS)
- REMOVE EXISTING SIGN, SALVAGE FOR REUSE
- LINE STRIPING TO BE REMOVED
- TEST PIT LOCATION
- PAVEMENT REMOVAL
- CONCRETE REMOVAL

NOTE: ALL DEMOLITION MATERIALS (PAVEMENT, SUBBASE REMOVED, ETC.) BECOME THE PROPERTY OF THE CONTRACTOR AND MUST BE REMOVED FROM SITE AND PROPERLY DISPOSED OF.

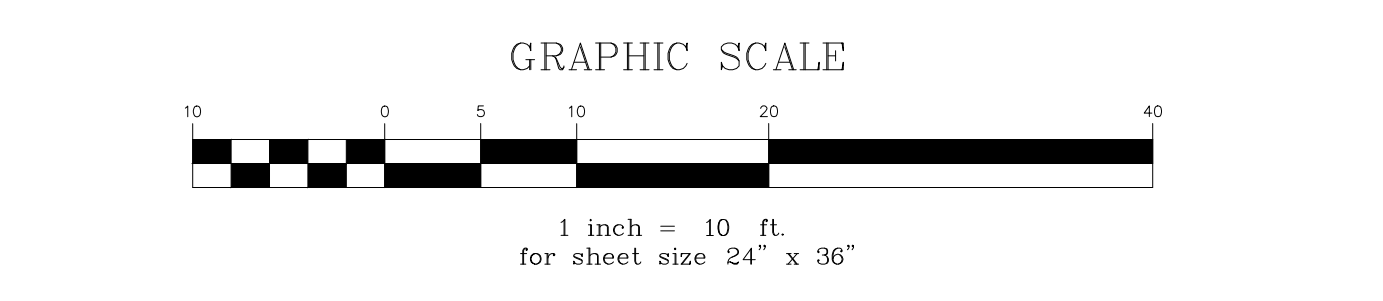

Stamp	
Date	
Description	
No.	

ENGINEERING VENTURES PC
 208 Pym Avenue, Suite 2A, Burlington, VT 05401 s 802-883-6225
 88 Mechanic Street, Suite E2-3, Lebanon, NH 03766 s 603-442-9333
 414 Union Street, Schenectady, NY 12305 s 518-630-9614
 www.engineeringventures.com

Town of Bristol Town Administrator c/o Valerie Caples, PO Box 249 1 South Street, Bristol, Vermont, 05443 802-453-2410 ext. 1	Demolition & EPSC Plan School Street Site Subsurface Infiltration Chamber Project Town of Bristol, Addison County, Vermont
---	--

EV Project #	21230
Drawn By:	HKW
Checked By:	PB
Scale:	1" = 10'
Date:	02/10/2022

C1.1

PLOTTED: 2/10/2022 10:13 AM

S:\PROJECTS\2021\2103 BRISTOL SUBSURFACE INFILTRATION CHAMBERS\DWG\2103 BRISTOL SCHOOL STREET C&S SITE PLAN.DWG

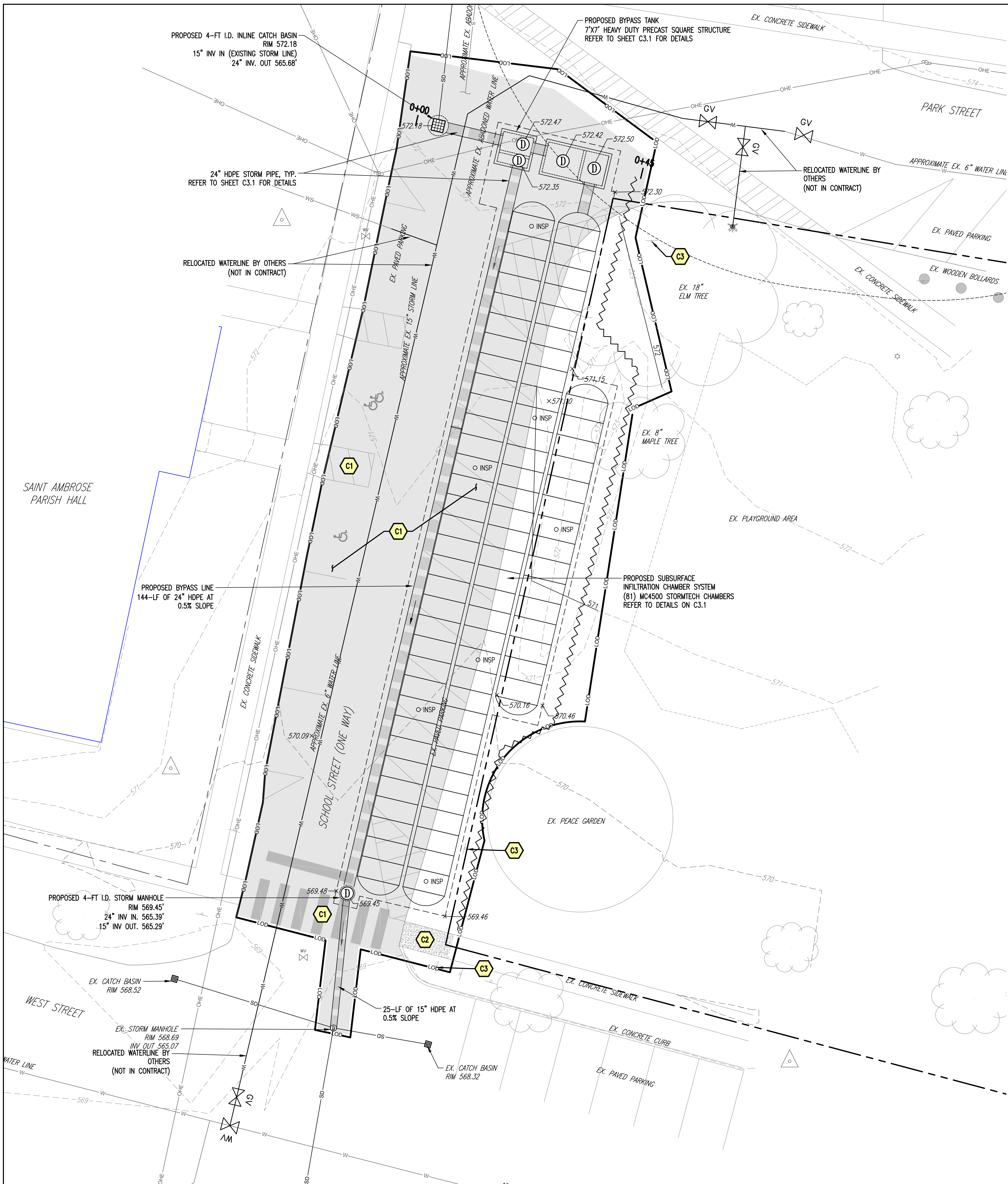

PROPOSED CONDITIONS LEGEND

- 670 5-FT CONTOUR INTERVAL
 - 671 1-FT CONTOUR INTERVAL
 - x-667.40 EXISTING SPOT GRADE ELEVATION
 - SD STORM LINE
 - CATCH BASIN/MANHOLE
 - INSP INSPECTION PORT LOCATION
 - DIRECTION OF PIPE FLOW
 - PROPOSED PAVEMENT REPLACEMENT
 - PROPOSED CONCRETE SIDEWALK REPLACEMENT
- NOTE: MATCH EXISTING GRADE WHERE FINISH GRADE CONTOURS ARE NOT INDICATED.
- REFER TO CHAMBER SYSTEM DETAILS ON SHEET C3.1.

PROPOSED SITE FEATURES

- C1 PROPOSED AREA OF PAVEMENT REPLACEMENT
RESTORE LINE STRIPING TO EXISTING CONDITION
- C2 PROPOSED AREA OF CONCRETE SIDEWALK REPLACEMENT
- C3 RESET SALVAGED SIGN

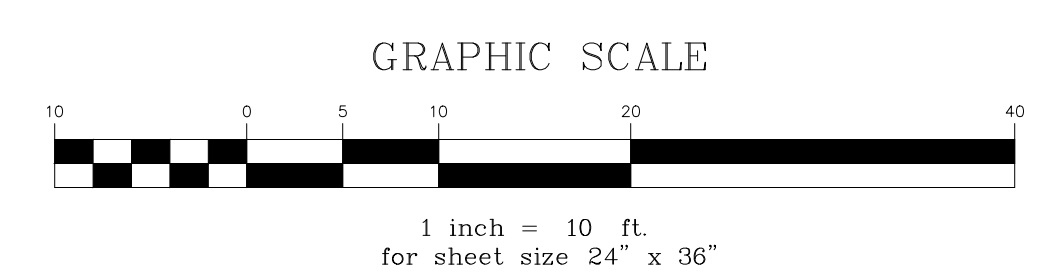

Stamp	
Date	
Description	
No.	
ENGINEERING VENTURES PC 208 Pym Avenue, Suite 2A, Burlington, VT 05401 s. 802-883-6225 85 Mechanic Street, Suite E2-3, Lebanon, NH 05766 s. 603-442-9333 414 Union Street, Schenectady, NY 12305 s. 518-630-9614 www.engineeringventures.com	
Town of Bristol c/o Valerie Caples, Town Administrator 1 South Street, PO Box 249 Bristol, Vermont 05443 802-453-2410 ext. 1	
Proposed Site Plan	School Street Site Subsurface Infiltration Chamber Project Town of Bristol, Addison County, Vermont
EV Project #	21230
Drawn By:	HKW
Checked By:	PB
Scale:	1" = 10'
Date:	02/10/2022
C2.0	

PLOTTED: 2/10/2022 10:12 AM

S:\PRODUCTS\2021\21030 BRISTOL SUB-SURFACE INFILTRATION CHAMBERS\DWG\SHEET\SECTIONAL STREET\SECTIONAL STREET C3.0 DETAILS.DWG

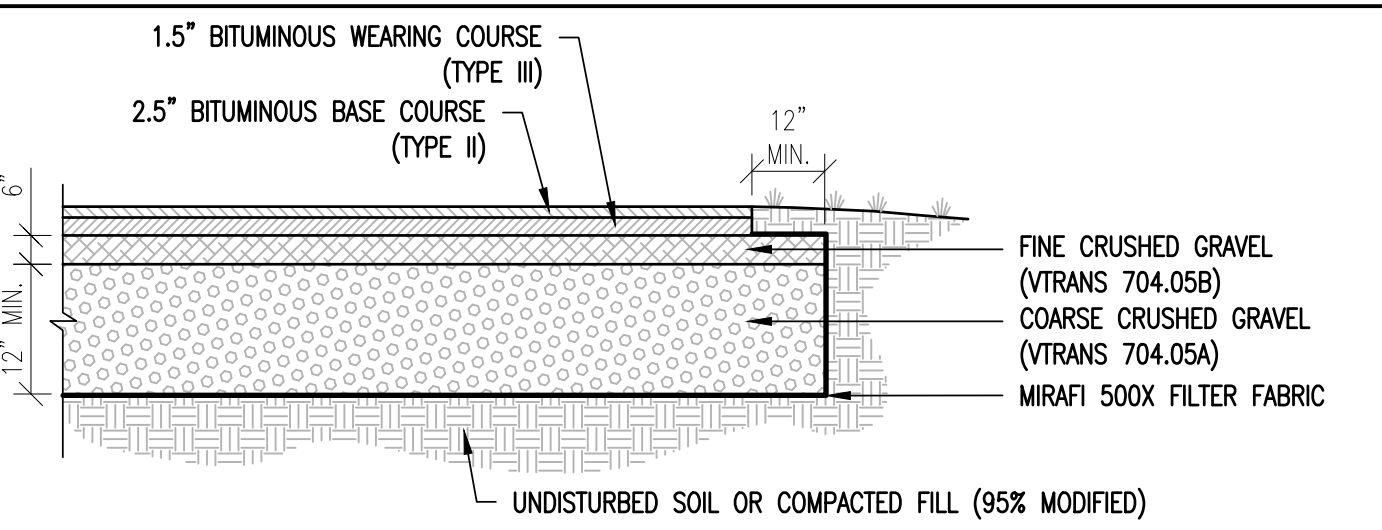

- NOTES:**
1. ALL SUBBASE MATERIALS SHALL BE PLACED IN 6" LIFTS AND COMPACTED TO 95% MAXIMUM DENSITY ACCORDING TO ASTM D-1557 (MODIFIED PROCTOR).
 2. ROAD PAVEMENT CROSS SECTION BASED ON VTRANS STANDARD SPECIFICATIONS FOR ROAD AND BRIDGE CONSTRUCTION.

PAVEMENT DETAIL NOT TO SCALE 1

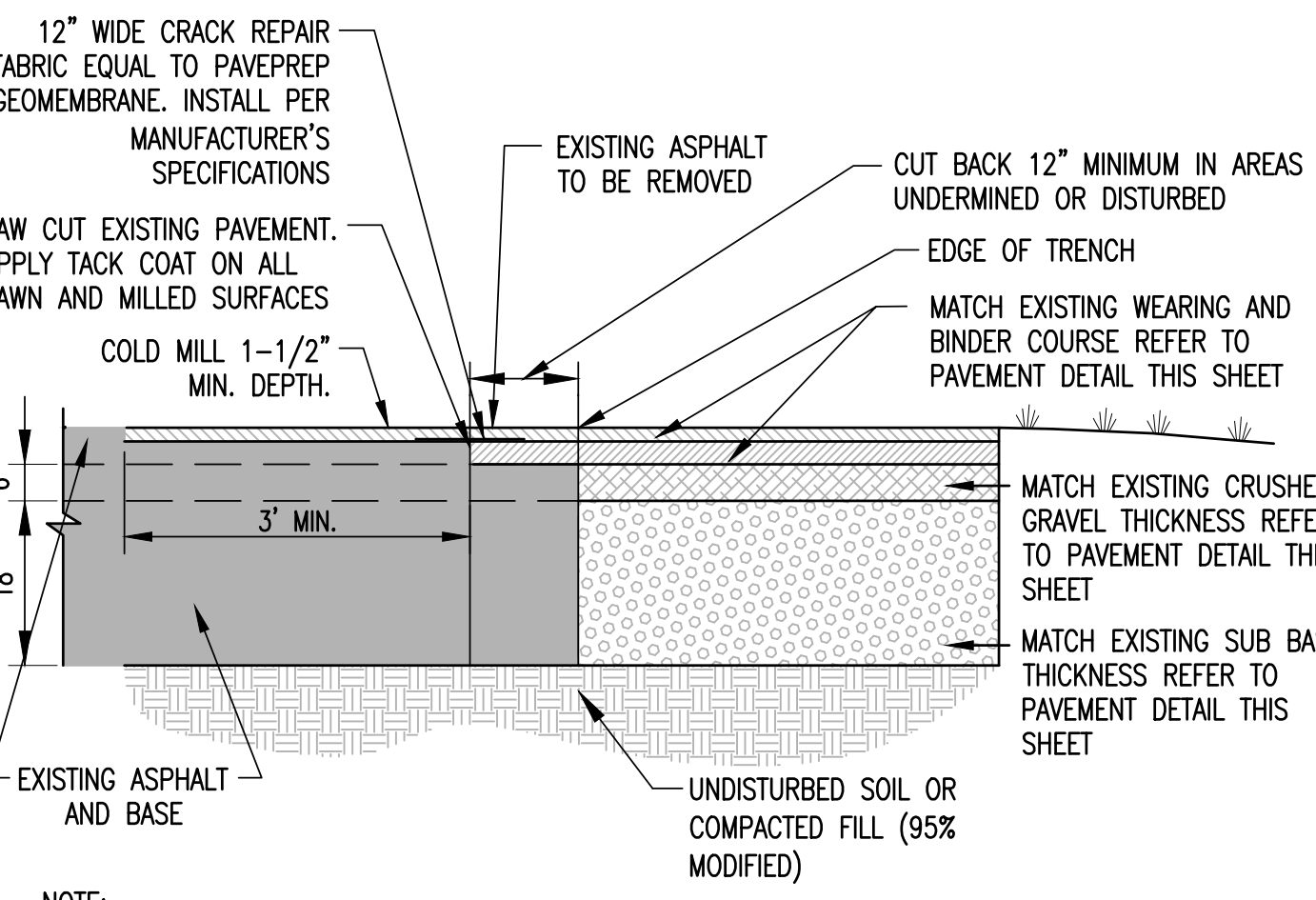

- NOTE:**
THIS METHOD OF PAVEMENT JOINT SHALL BE USED FOR ANY APPLICATION OR CONSTRUCTION WHERE PROPOSED PAVEMENT AND BASE WILL BE CONNECTED TO EXISTING PAVEMENT AND BASE.

TRENCH CROSS SECTION DETAIL

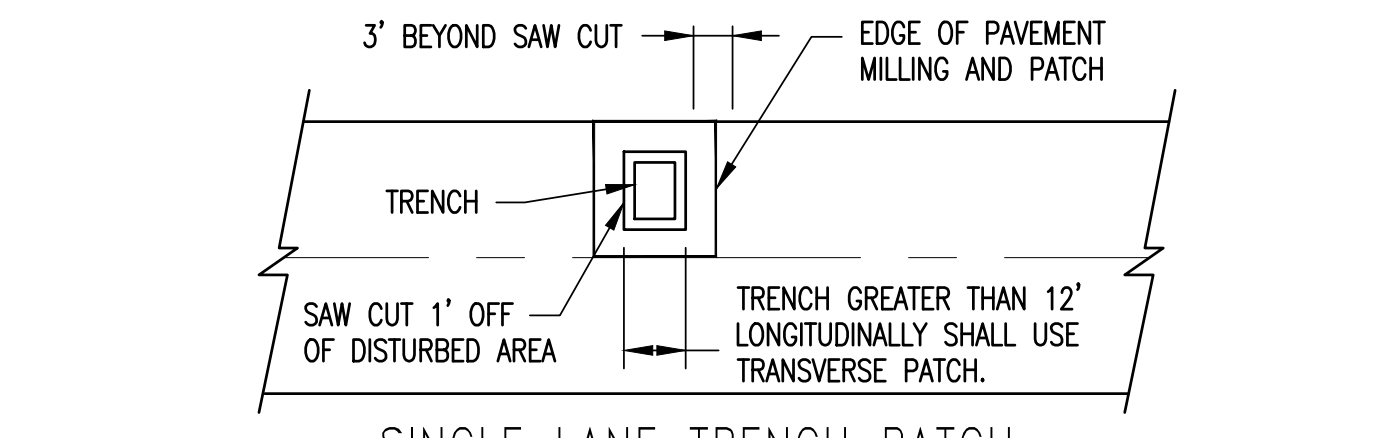

SINGLE LANE TRENCH PATCH

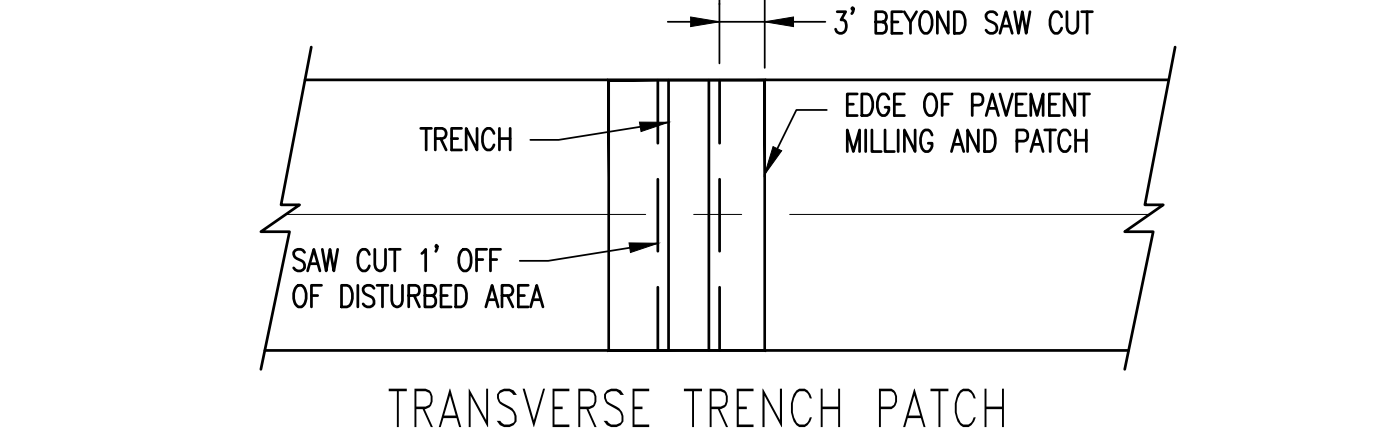

TRANSVERSE TRENCH PATCH

ASPHALT PAVEMENT TRENCH PATCH DETAIL NOT TO SCALE 2

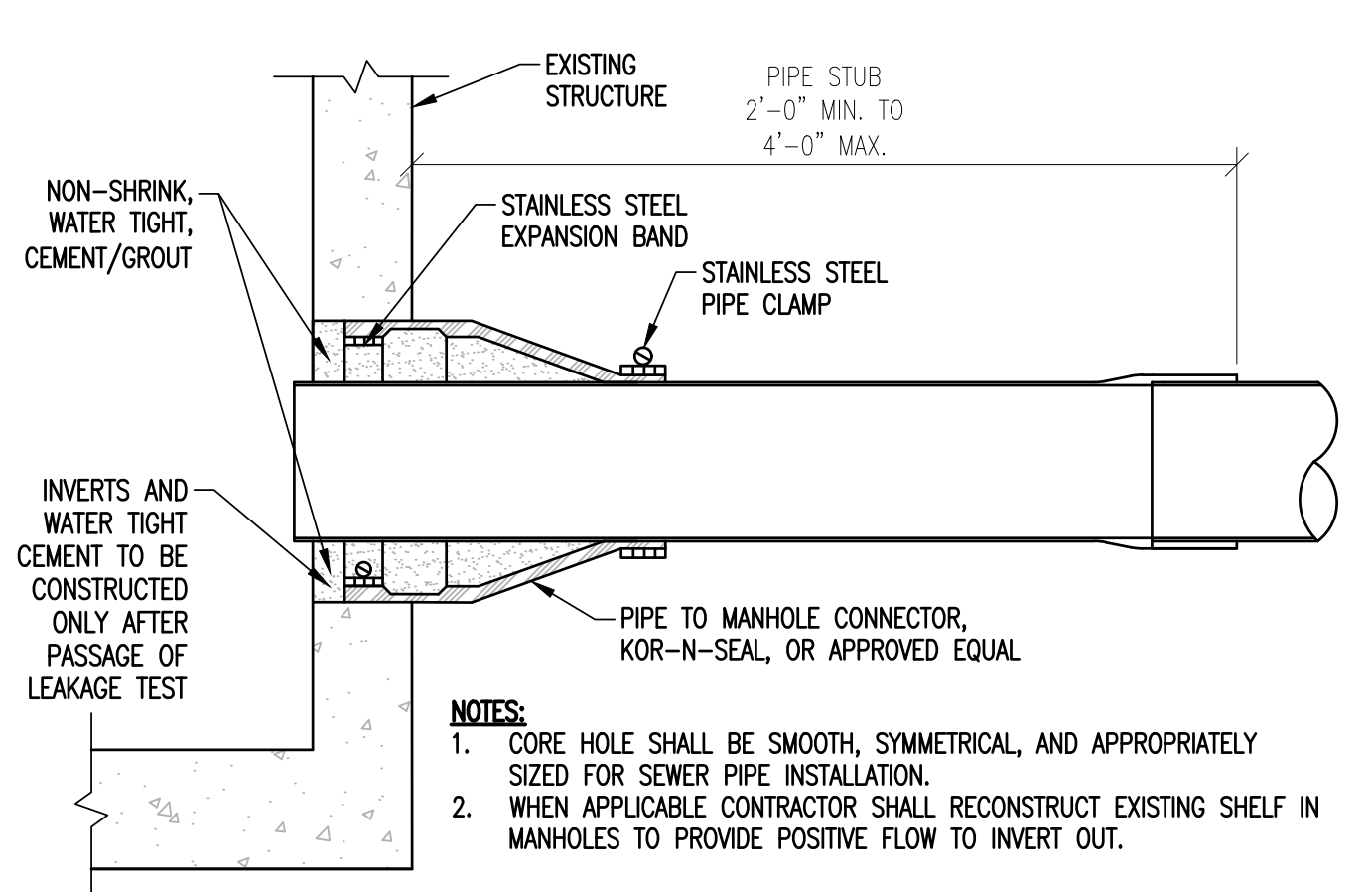

- NOTES:**
1. CORE HOLE SHALL BE SMOOTH, SYMMETRICAL, AND APPROPRIATELY SIZED FOR SEWER PIPE INSTALLATION.
 2. WHEN APPLICABLE CONTRACTOR SHALL RECONSTRUCT EXISTING SHELF IN MANHOLES TO PROVIDE POSITIVE FLOW TO INVERT OUT.

STRUCTURE PIPE CONNECTION NOT TO SCALE 3

INSULATION IN PAVED AREAS:			INSULATION IN UNPAVED AREAS:		
COVER	INSUL. WIDTH	INSUL. THICKNESS	COVER	INSUL. WIDTH	INSUL. THICKNESS
0'-3"	LOWER DRAIN	3"	0'-2"	LOWER DRAIN	3"
3'-4"	4'-0"	3"	2'-3"	4'-0"	3"
4'-6"	4'-0"	2"	3'-5"	4'-0"	2"
> 6"	NO INSUL. REQUIRED		> 5"	NO INSUL. REQUIRED	

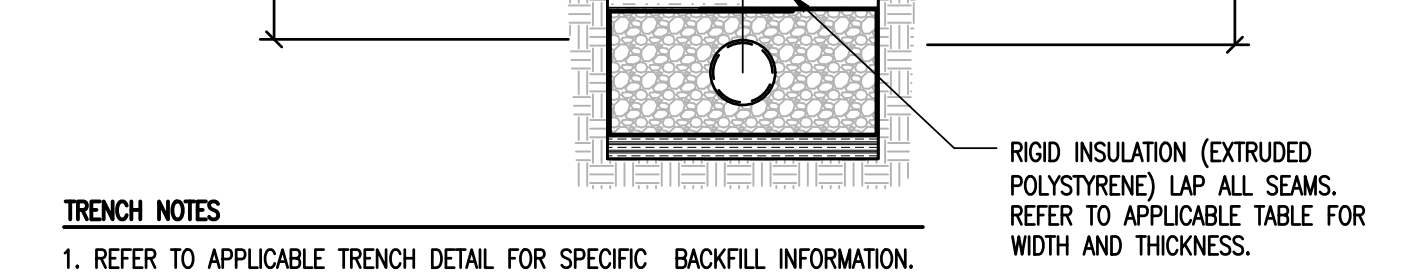

INSULATION OVER SHALLOW DRAIN DETAIL NOT TO SCALE 4

TYPICAL STORM DRAIN TRENCH DETAIL NOT TO SCALE 5

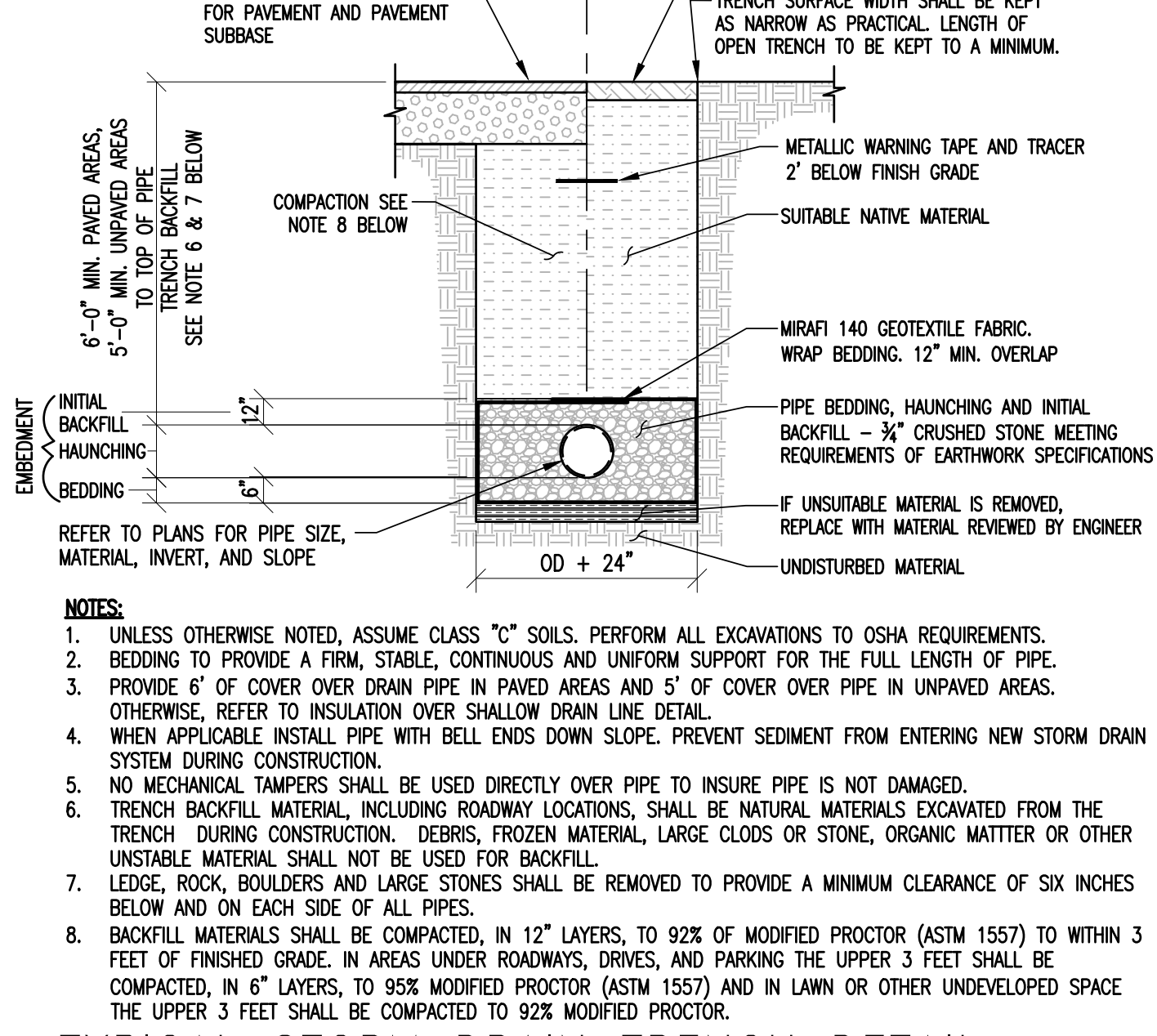

TYPICAL STORM DRAIN TRENCH DETAIL NOT TO SCALE 5

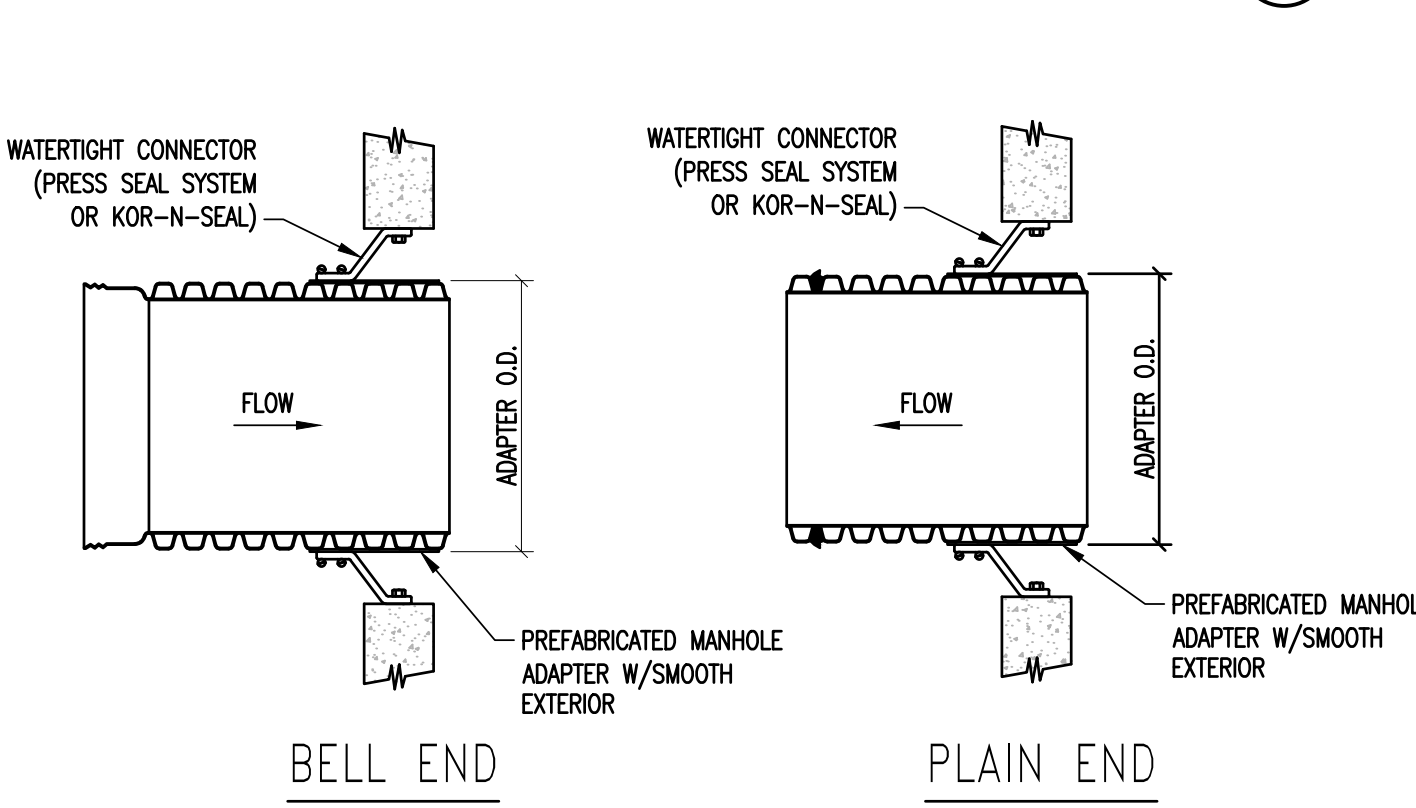

- GENERAL NOTES:**
1. PERFORMANCE HIGHLY DEPENDENT ON INSTALLATION. CONTRACTOR MUST ENSURE MANHOLE GASKET IS UNIFORMLY SEATED AROUND STRUCTURE ADAPTER. EXTRA PRECAUTIONS MUST BE TAKEN TO PREVENT DIFFERENTIAL SETTLEMENT BETWEEN THE PIPE AND MANHOLE.

STORM DRAIN MANHOLE/CATCHBASIN CONNECTION NOT TO SCALE 6

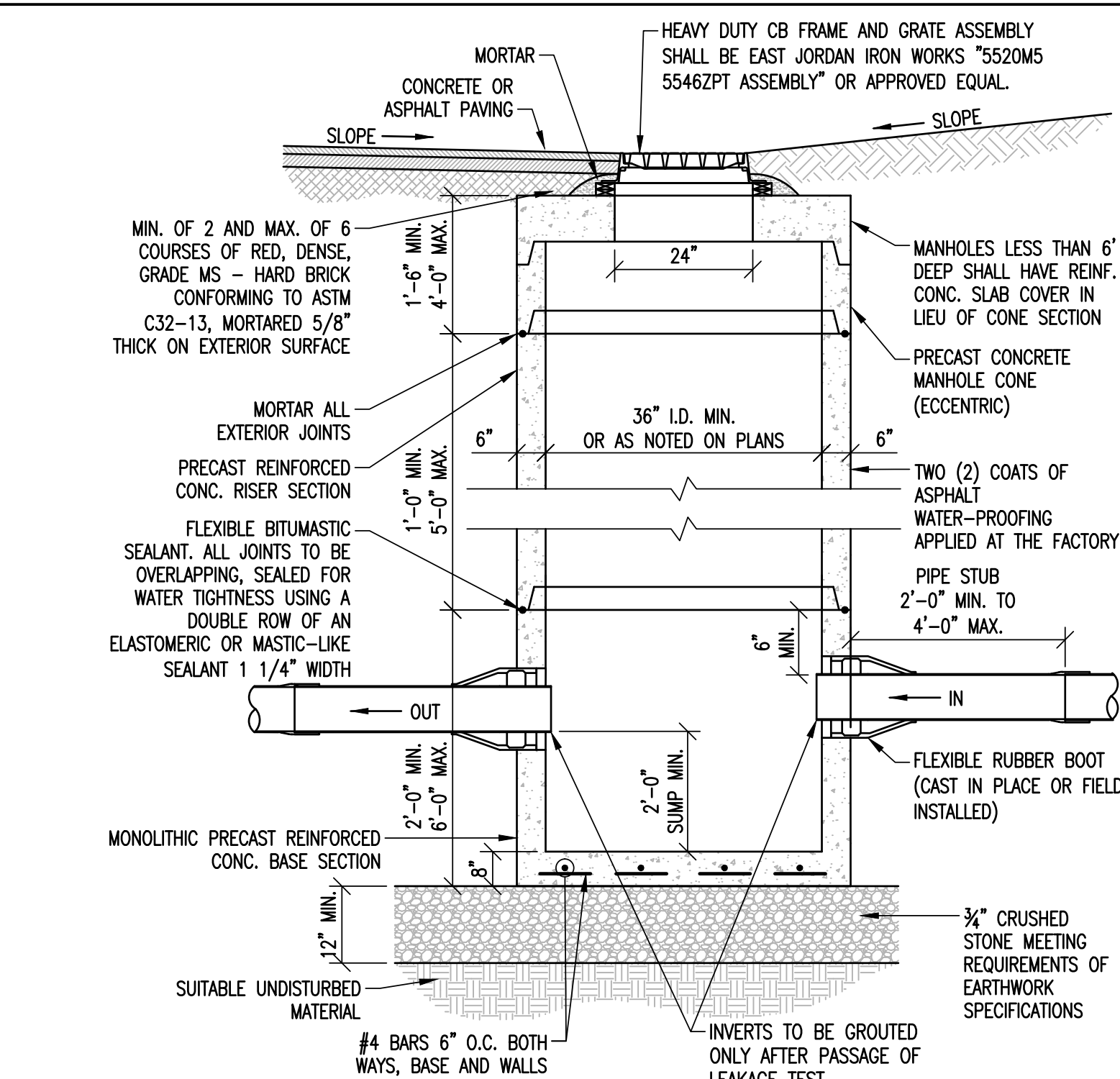

- NOTES:**
1. IF DEPTH OF MANHOLE IS 6 FT. OR LESS FROM RIM TO CENTERLINE INVERT, THEN A FLAT TOP WILL BE INSTALLED. IF DEPTH OF MANHOLE FROM RIM TO CENTERLINE INVERT IS MORE THAN 6 FT., THEN AN ECCENTRIC CONICAL TOP WILL BE INSTALLED.
 2. CATCH BASIN AND GRATE SHALL BE DESIGNED FOR H20 LOADING.

CATCH BASIN DETAIL NOT TO SCALE 7

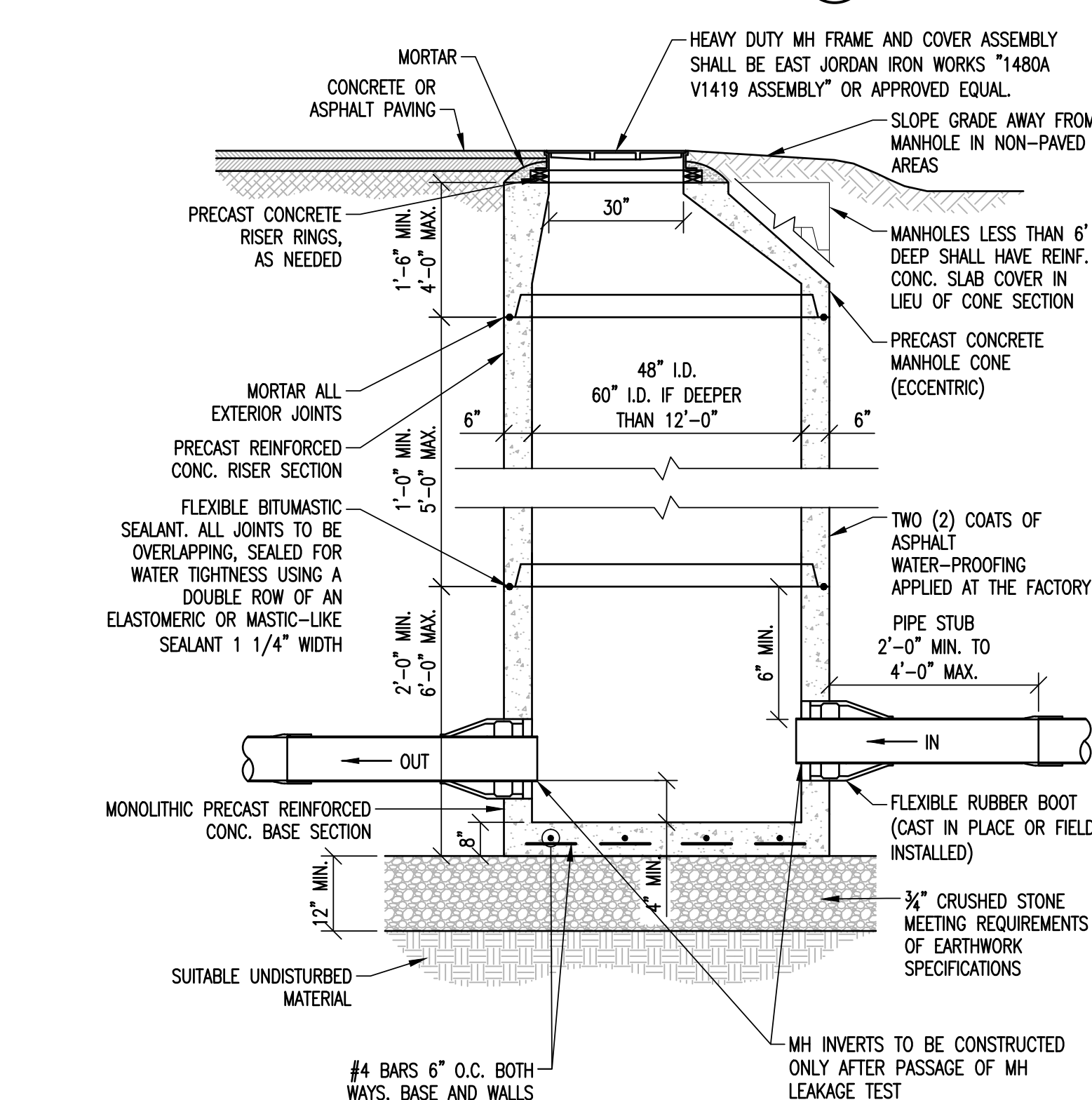

- NOTES:**
1. PROVIDE SMOOTH SWEEPING TRANSITIONS BETWEEN INVERTS OF INTERSECTING PIPE.
 2. IF DEPTH OF MANHOLE IS 6 FT. OR LESS FROM RIM TO CENTERLINE INVERT, THEN A FLAT TOP WILL BE INSTALLED. IF DEPTH OF MANHOLE FROM RIM TO CENTERLINE INVERT IS MORE THAN 6 FT., THEN AN ECCENTRIC CONICAL TOP WILL BE INSTALLED.
 3. INVERTS AND SHELVES SHALL BE PLACED AFTER TESTING.
 4. MANHOLE AND COVER SHALL BE DESIGNED FOR H20 LOADING.

DRAINAGE MANHOLE DETAIL NOT TO SCALE 8

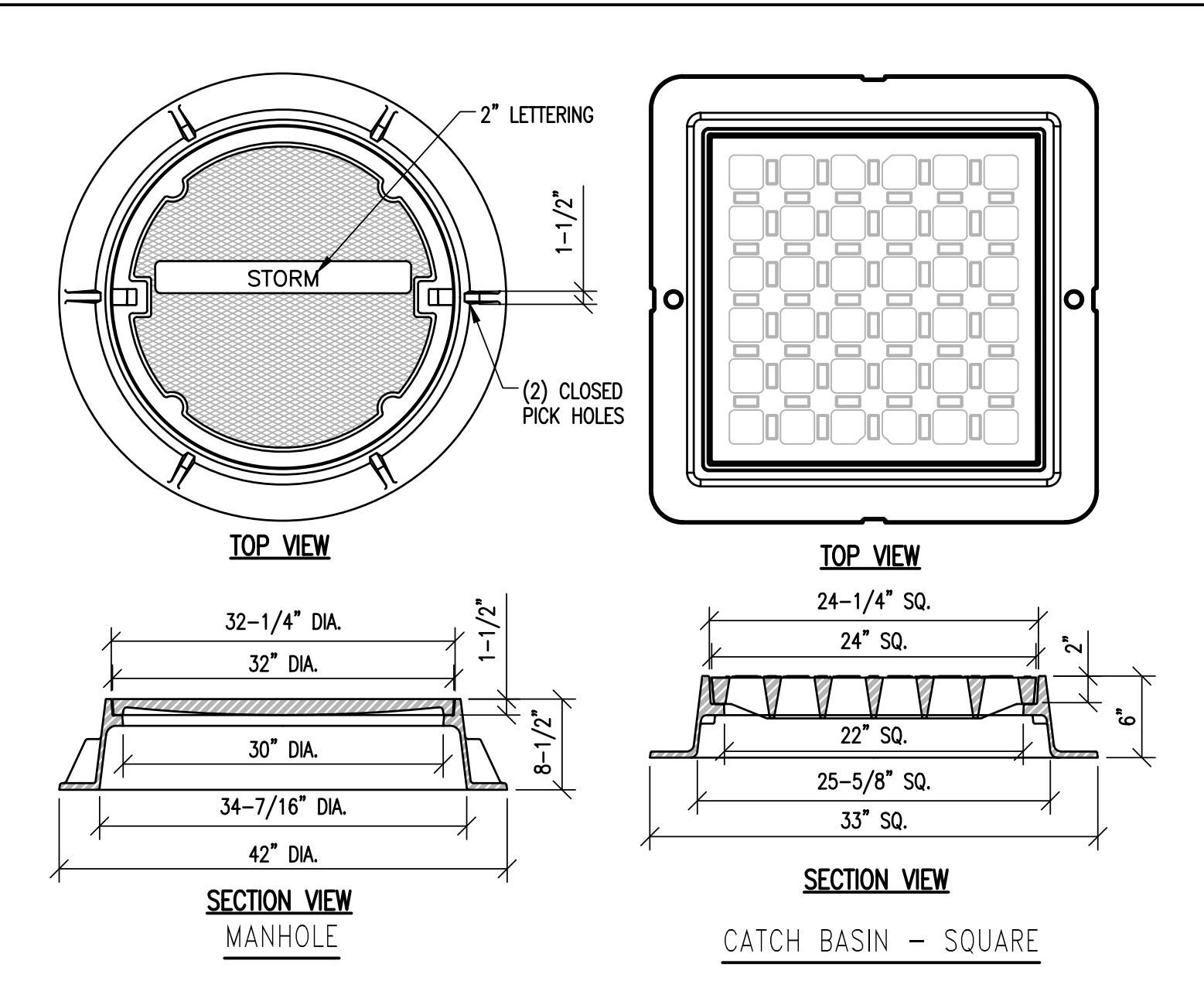

- NOTES:**
1. ALL DIMENSIONS SHOWN HERE ARE NOMINAL.
 2. COVER SHALL BE HEAVY DUTY (H-20) LOAD RATED.
 3. CATCH BASIN (SQUARE) FRAME AND GRATE ASSEMBLY SHALL BE EAST JORDAN IRON WORKS FRAME 5546Z (PRODUCT NUMBER 00554611 (4 FLANGE) OR APPROVED EQUAL).
 3. CATCH BASIN (ROUND) FRAME AND GRATE ASSEMBLY SHALL BE EAST JORDAN IRON WORKS \"22662 1040M3 SET\" (PRODUCT NUMBER 00211033205) OR APPROVED EQUAL.
 3. MANHOLE (MH) FRAME AND COVER ASSEMBLY SHALL BE EAST JORDAN IRON WORKS \"1480A V1419 ASSEMBLY\" OR APPROVED EQUAL.

STORMWATER MH COVERS AND CB GRATES NOT TO SCALE 9

EARTHWORK SPECIFICATIONS

1. PRIOR TO THE START OF THE WORK, A PRE-CONSTRUCTION MEETING WILL BE HELD WITH THE TOWN DPW CONSTRUCTION ADMINISTRATOR, CONTRACTOR, OWNER & PROJECT ENGINEERS TO REVIEW PROCEDURES, IDENTIFY RESPONSIBILITIES. UNLESS STATED OTHERWISE, ALL MATERIALS AND METHODS SHALL BE IN ACCORDANCE WITH THE MOST RECENT VERSION OF THE APPLICABLE STATE STANDARD SPECIFICATIONS FOR ROAD AND BRIDGE CONSTRUCTION.
2. CLEARING AND GRUBBING- ALL TOPSOIL AND UNSUITABLE MATERIALS SHALL BE REMOVED FROM THE DRIVEWAY, PARKING LOT, AND SIDEWALK LIMITS. THE DRIVEWAY AND PARKING LOT BASE MATERIAL SHALL EXTEND ONE FOOT BEYOND THE EDGE OF PAVING.
3. BASE COURSE- THE BASE COURSE SHALL CONSIST OF TWELVE INCHES OF DENSE GRADED GRAVEL AND SIX INCHES OF FINE CRUSHED GRAVEL. GRADATION CURVES COMPLYING WITH THE EARTHWORK SPECIFICATIONS SHALL BE PROVIDED FOR THE ENGINEERS REVIEW PRIOR TO CONSTRUCTION.
4. COMPACTION SHALL BE PERFORMED USING VIBRATORY ROLLERS AND WATER IN LIFTS OF NO GREATER THAN TWELVE INCHES. COMPACTION SHALL BE PERFORMED UNTIL THE REQUIRED DENSITY IS ACHIEVED. DENSITY SHALL BE DETERMINED BY AASHTO T238 METHOD AND SHALL NOT BE LESS THAN 95 PERCENT OF THE MAXIMUM DENSITY DETERMINED IN ACCORDANCE WITH AASHTO 199.
5. COMPACTION TESTING SHALL BE PERFORMED FOR EVERY LAYER OF MATERIAL PLACED AND FOR EVERY 1000 SQUARE FEET OF AREA.
6. PAVEMENT SHALL MEET APPLICABLE STATE STANDARD SPECIFICATIONS FOR ROAD AND BRIDGE CONSTRUCTION REQUIREMENTS, IN ADDITION TO APPLICABLE TOWN ROAD STANDARDS.
7. PAVEMENT SHALL NOT BE INSTALLED WHEN THE OUTSIDE AIR TEMPERATURE IS BELOW 40 DEGREES FAHRENHEIT, NOR WHEN THE ROAD BASE TEMPERATURE IS BELOW 40 DEGREES FAHRENHEIT. PAVEMENT SHALL NOT FALL BELOW 185 DEGREES FAHRENHEIT PRIOR TO THE COMPLETION OF ROLLING. PAVEMENT SHALL NOT BE INSTALLED WHEN THE SUBGRADE IS FROZEN OR THE GRADES ARE INCORRECT.
8. ALL REMAINING DISTURBED AREAS WITHIN THE RIGHT OF WAY SHALL BE FERTILIZED AND SEEDED IN ACCORDANCE WITH APPLICABLE STATE SPECIFICATIONS.
9. THE SEEDING OF SLOPES AND DITCHES SHALL REQUIRE THE USE OF EROSION CONTROL MATTING.
10. COST OF INITIAL INSPECTION AND TESTING SHALL BE PAID BY THE OWNER. SUBSEQUENT TESTING DUE TO FAILURE SHALL BE PAID BY THE CONTRACTOR.
11. ALL EARTHWORK MATERIALS SHALL BE OBTAINED FROM APPROVED SOURCES. THEY SHALL CONSIST OF SATISFACTORILY GRADED, FREE DRAINING MATERIAL, REASONABLY FREE FROM LOAM, SILT, CLAY AND ORGANIC MATERIAL. EARTHWORK MATERIALS SHALL MEET THE REQUIREMENTS OF THE PROJECT SPECIFICATIONS.

Date		Stamp	
Description		No.	
		Town of Bristol c/o Valerie Caples, Town Administrator 1 South Street, PO Box 249 Bristol, Vermont, 05413 802-453-2410 ext. 1	
208 Flynn Avenue, Suite 2A, Burlington, VT 05401 s. 802-883-8225 85 Merchant Street, Suite E2-3, Lebanon, NH 03766 s. 603-442-9333 414 Union Street, Schenectady, NY 12305 s. 518-630-9814 www.engineeringventures.com		Site & Stormwater Details School Street Site Subsurface Infiltration Chamber Project Town of Bristol, Addison County, Vermont	
EV Project #	21230	Drawn By:	HKW
Checked By:	PB	Scale:	not to scale
Date:	02/10/2022		
C3.0			

PLotted: 21/10/22 10:12 AM
 S:\PRODUCTS\2021\2100 BRISTOL SUB-SURFACE INFILTRATION CHAMBERS\DWGS\DWGS\SHEET\FILED\SCHOOL STREET CL3.3 DETAILS.DWG

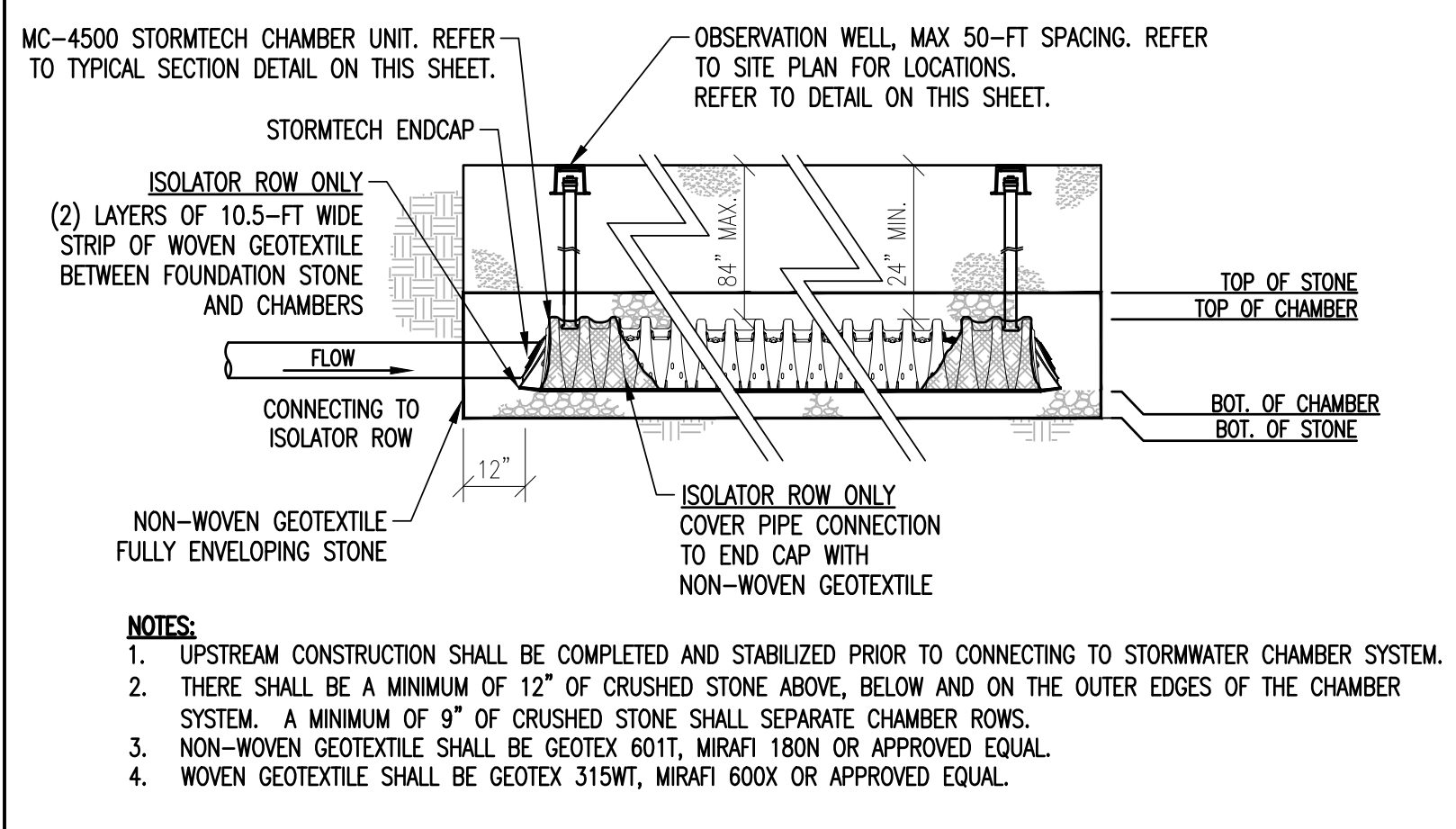

STORMTECH CHAMBER SYSTEM NOT TO SCALE 1

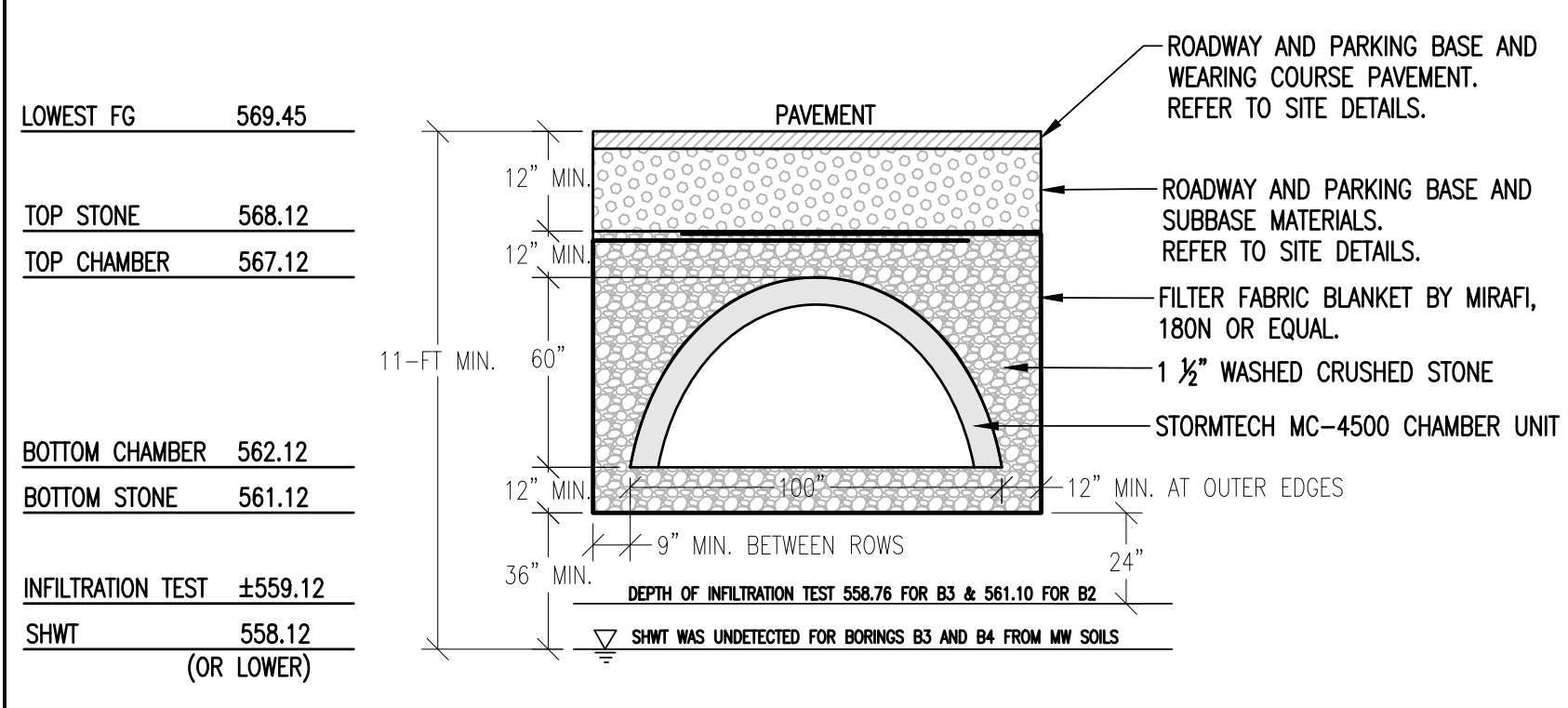

STORMTECH CHAMBER TYPICAL SECTION NOT TO SCALE 2

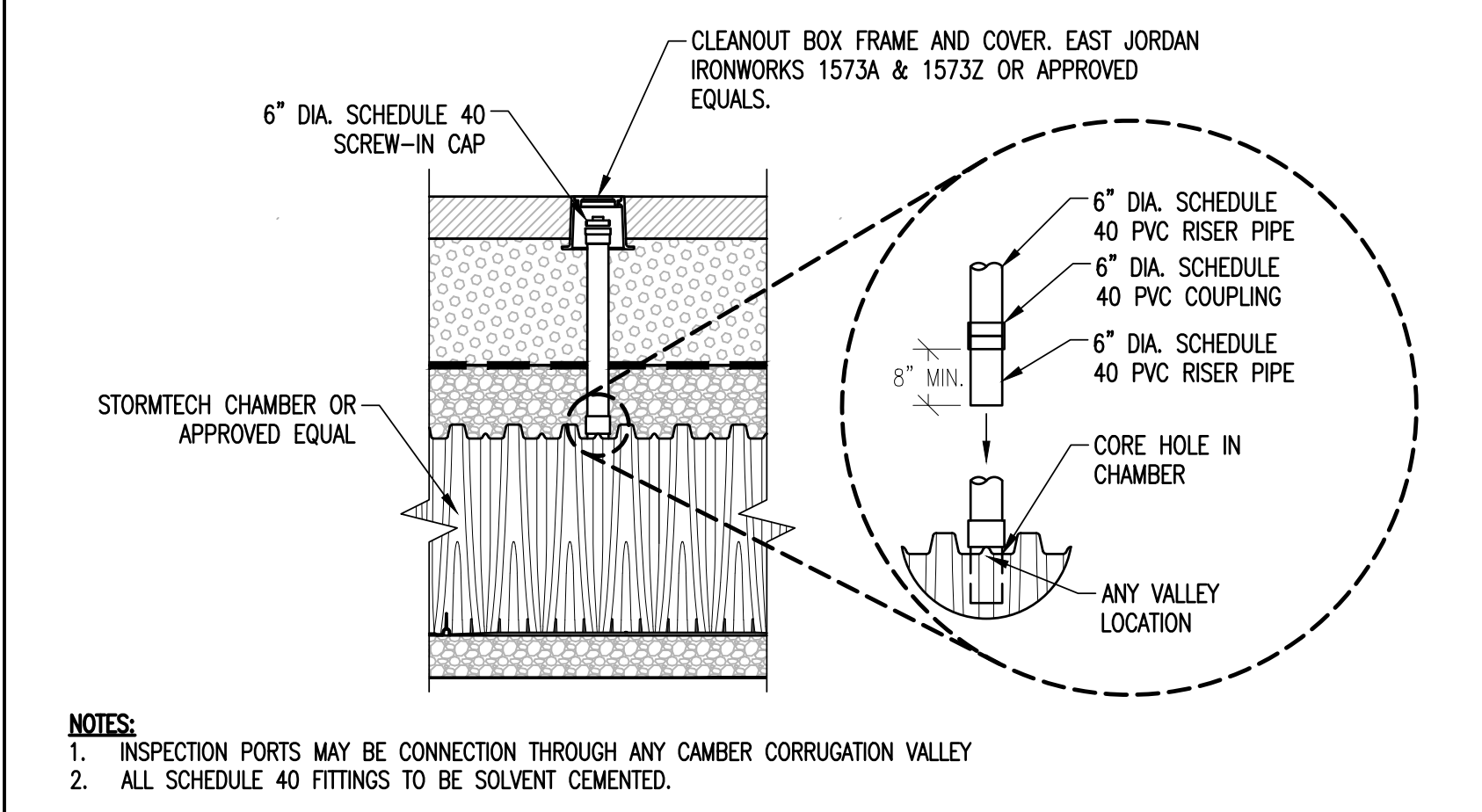

CHAMBER INSPECTION PORT DETAIL NOT TO SCALE 3

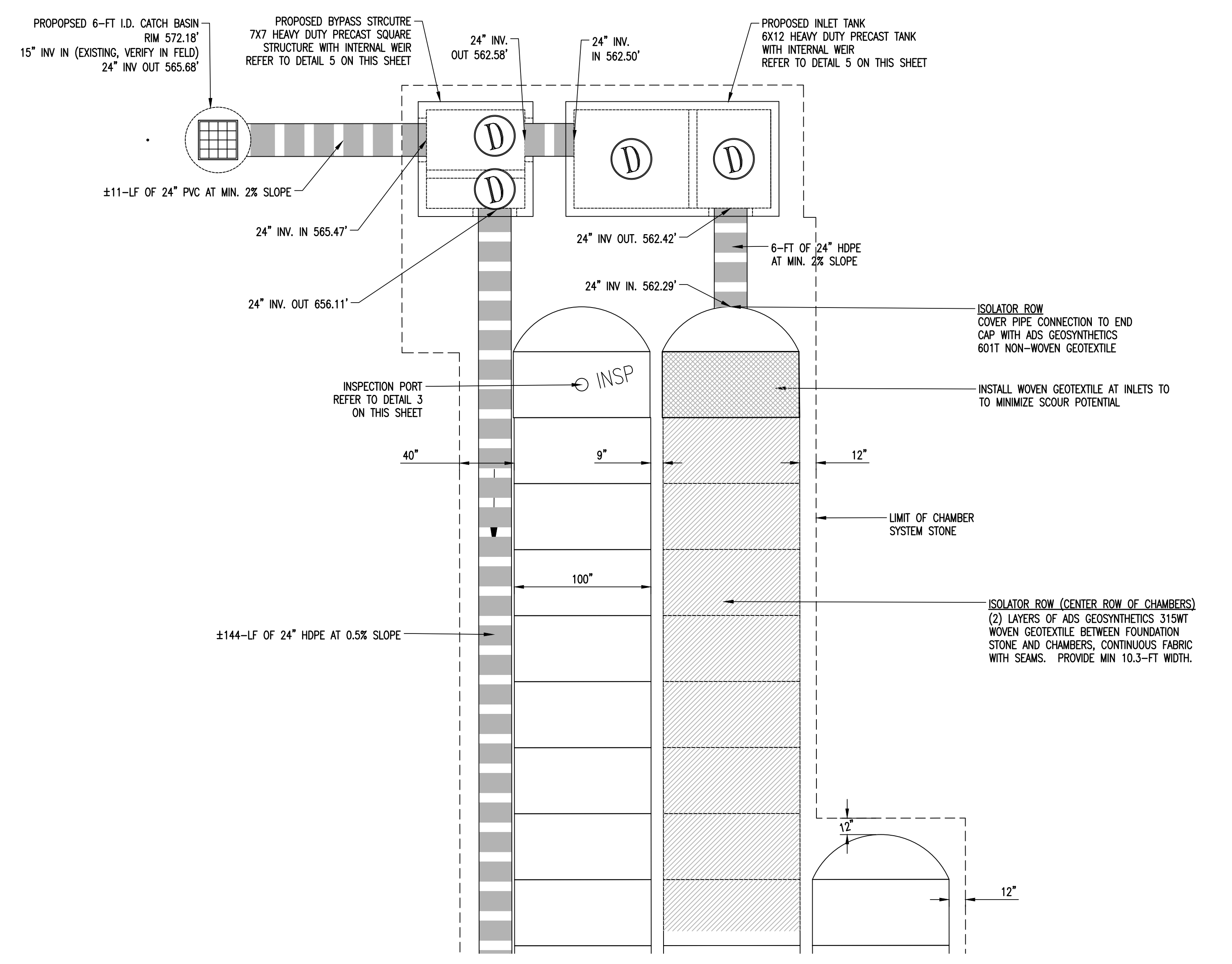

CHAMBER SYSTEM INLET CONFIGURATION DETAIL NOT TO SCALE 4

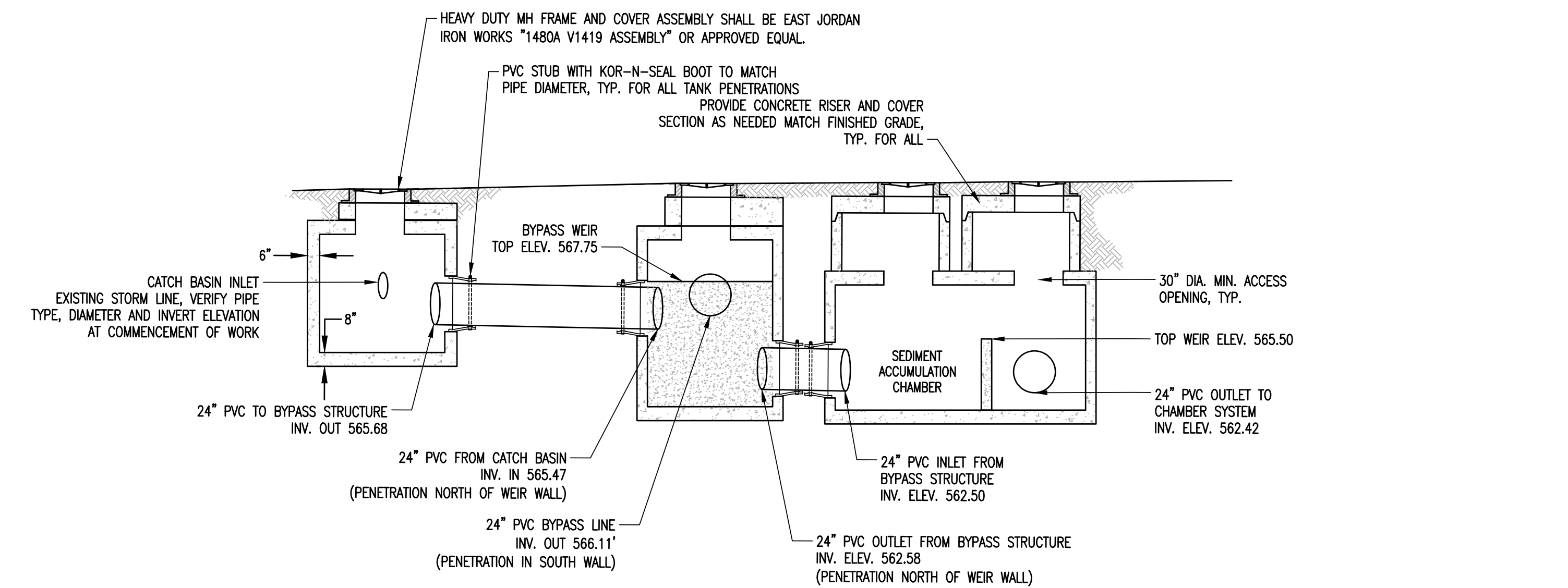

BYPASS TANK DETAIL NOT TO SCALE 5

	Stamp
Date	
Description	
No.	
<p>ENGINEERING VENTURES PC</p> <p>208 Flynn Avenue, Suite 2A, Burlington, VT 05401 s. 802-883-8225 85 Mechanic Street, Suite E2-3, Lebanon, NH 03766 s. 603-449-9333 414 Union Street, Schenectady, NY 12305 s. 518-830-9614 www.engineeringventures.com</p>	
<p>Town of Bristol c/o Valerie Caples, Town Administrator 1 South Street, PO Box 249 Bristol, Vermont 05443 802-453-2410 ext. 1</p>	
Sheet Title:	<p>Chamber System Details</p> <p>School Street Site Subsurface Infiltration Chamber Project Town of Bristol, Addison County, Vermont</p>
Project Title:	
EV Project #	21230
Drawn By:	HKW
Checked By:	PB
Scale:	not to scale
Date:	02/10/2022
C3.1	

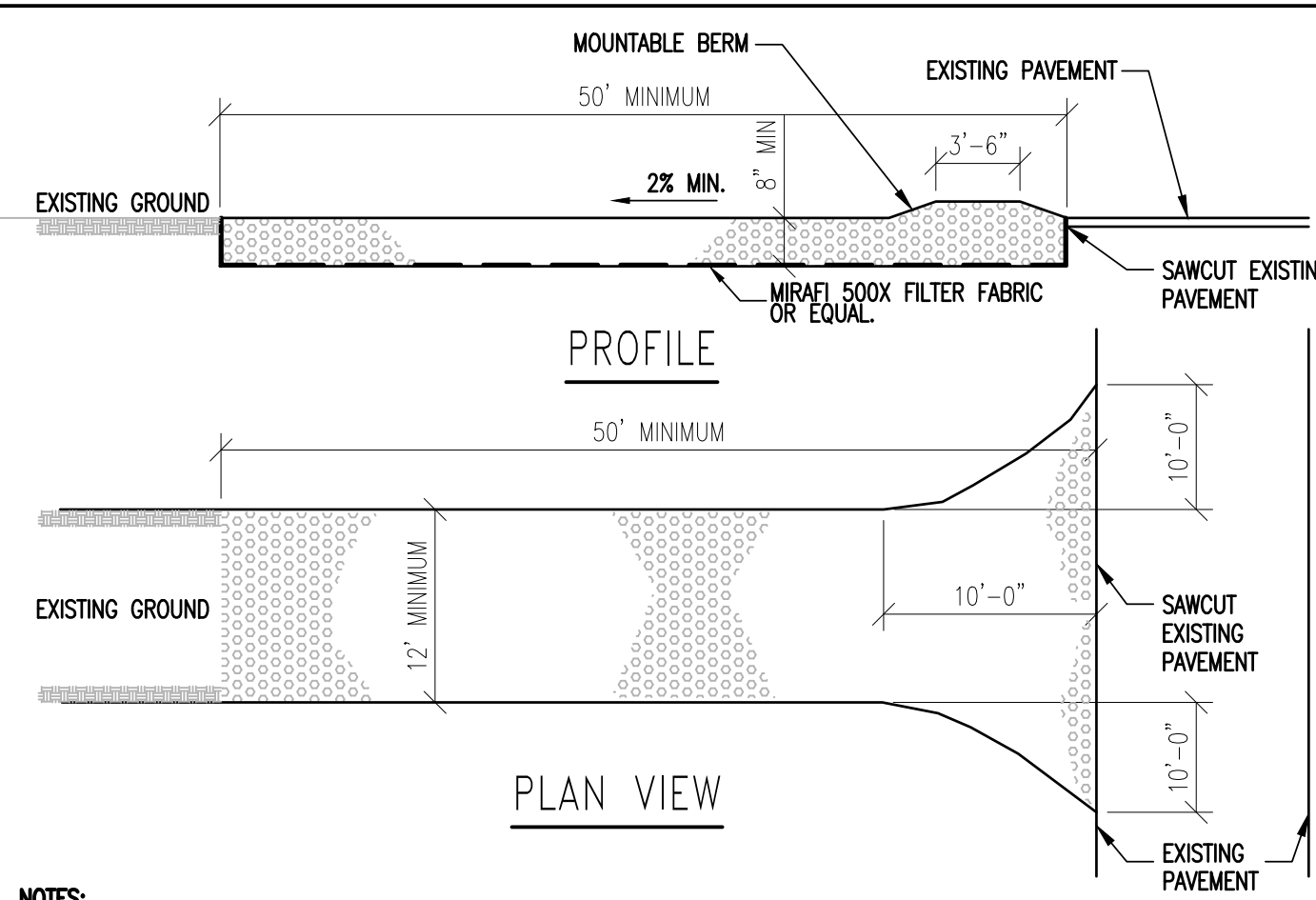

- NOTES:**
- STONE SIZE: USE TYPE I STONE MEETING REQUIREMENTS OF EARTHWORK SPECIFICATIONS.
 - SURFACE WATER - ALL SURFACE WATER FLOWING OR DIVERTED TOWARD CONSTRUCTION ENTRANCE SHALL BE PIPED ACROSS THE ENTRANCE.
 - MAINTENANCE - THE ENTRANCE SHALL BE MAINTAINED IN A CONDITION WHICH WILL PREVENT TRACKING OR FLOWING OF SEDIMENT ONTO PUBLIC RIGHT-OF-WAYS. THIS MAY REQUIRE PERIODIC TOP DRESSING WITH ADDITIONAL STONE AS CONDITIONS DEMAND. REPAIR AND/OR CLEANOUT ANY MEASURES USED TO TRAP SEDIMENT, TRACKING ONTO PUBLIC RIGHT-OF-WAYS SHALL NOT BE ALLOWED. ALL SEDIMENT SPILLED, DROPPED, OR WASHED ONTO PUBLIC RIGHT-OF-WAYS MUST BE REMOVED IMMEDIATELY AND ANY WASH WATER MUST BE CONTAINED AND PROPERLY DISPOSED OF.
 - PERIODIC INSPECTION AND NEEDED MAINTENANCE SHALL BE PROVIDED AFTER EACH RAIN.
 - WHEELS SHALL BE CLEANED TO REMOVE MUD PRIOR TO ENTRANCE ONTO PUBLIC RIGHT-OF-WAY. WHEN WASHING IS REQUIRED, IT SHALL BE DONE ON AN AREA STABILIZED WITH STONE WHICH DRAINS INTO AN APPROVED SEDIMENT TRAPPING DEVICE.

STABILIZED CONSTRUCTION ENTRANCE DETAIL

NOT TO SCALE

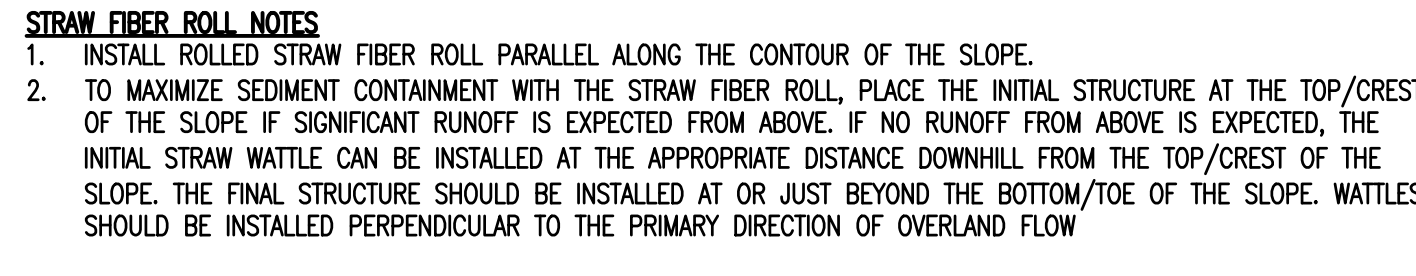

STRAW FIBER ROLL - SOIL

NOT TO SCALE

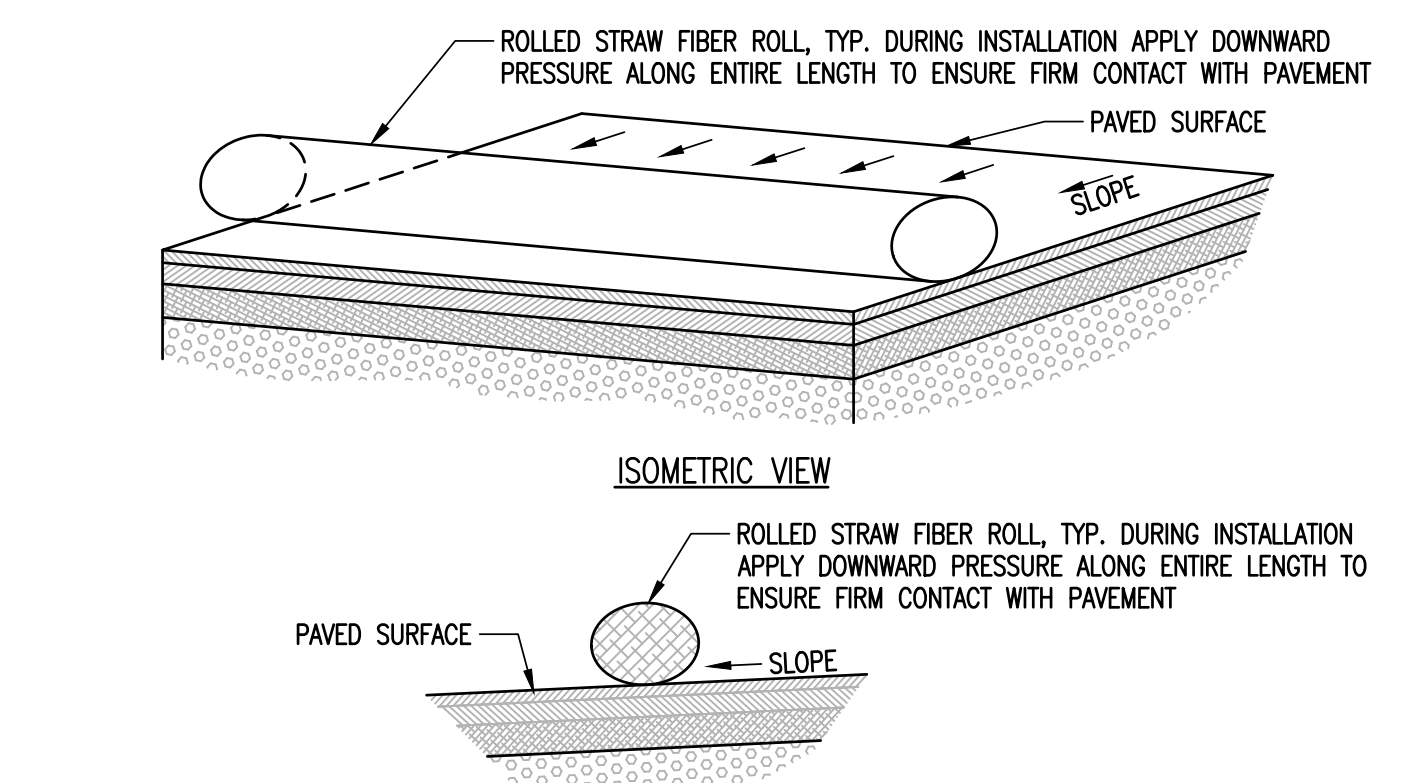

STRAW FIBER ROLL - PAVEMENT

NOT TO SCALE

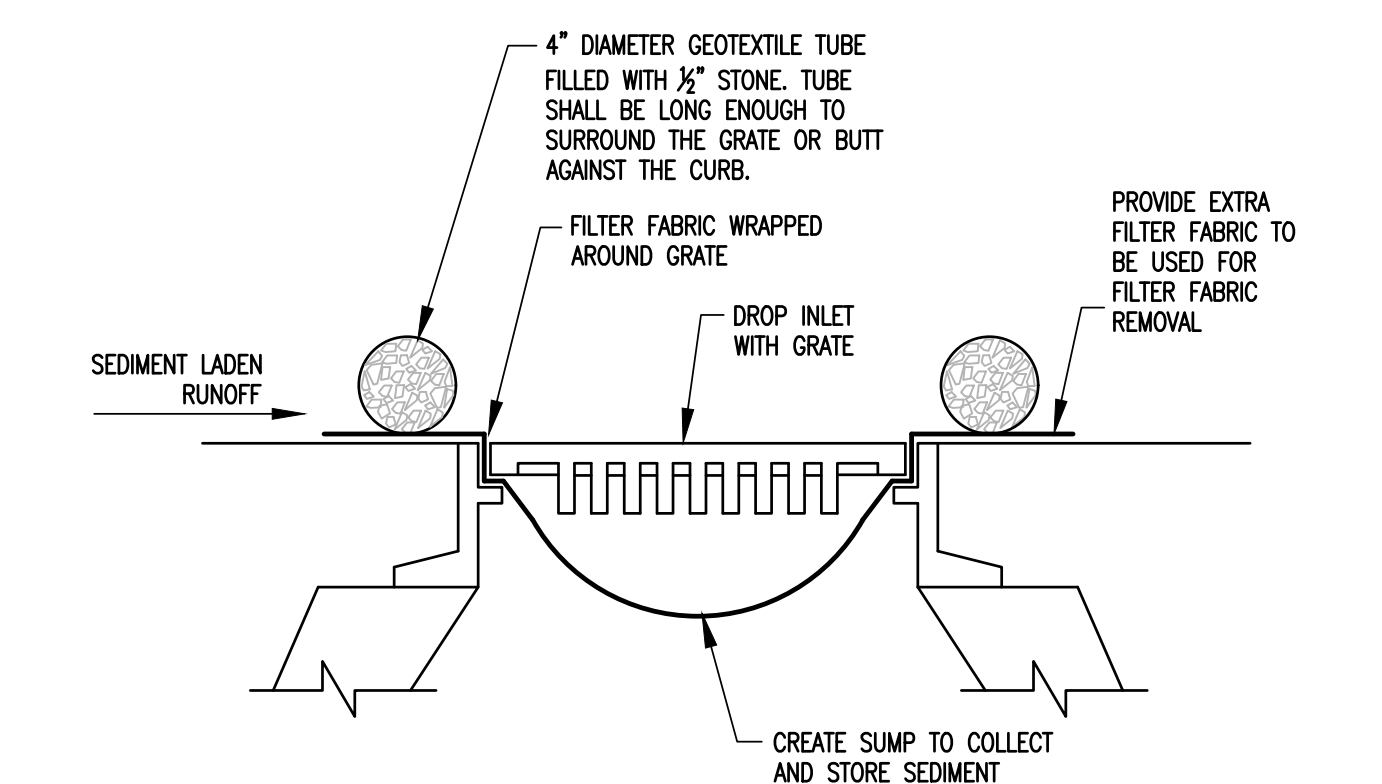

INLET PROTECTION DETAIL

NOT TO SCALE

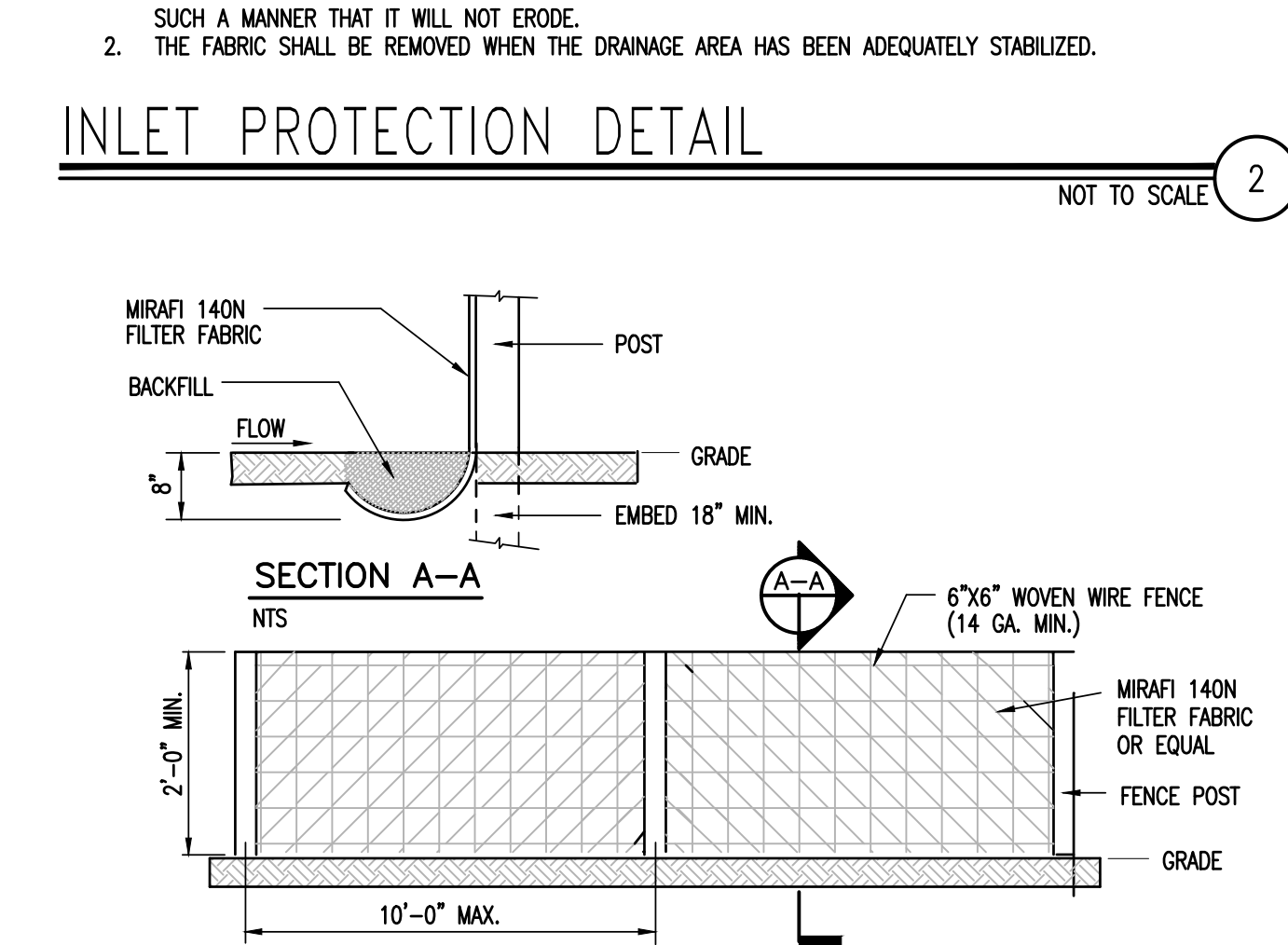

SILT FENCE DETAIL

NOT TO SCALE

- NOTES:**
- SILT FENCE SHALL BE PRE-FABRICATED EROSION CONTROL FENCE BY MIRAFL OR EQUAL, OR CONSTRUCTED IN PLACE AS SPECIFIED HEREIN.
 - CONSTRUCTED IN PLACE SILT FENCE:
 - WOVEN WIRE FENCE TO BE FASTENED SECURELY TO FENCE POSTS WITH WIRE TIES OR STAPLES.
 - FILTER FABRIC TO BE FASTENED SECURELY TO WOVEN WIRE FENCE TIES SPACED EVERY 24" AT TOP OF MID SECTION.
 - WHEN TWO SECTIONS OF FILTER CLOTH ADJOIN EACH OTHER, THEY SHALL BE OVERLAPPED BY 6", FOLDED AND STAPLED.
 - INSPECTION SHALL BE FREQUENT (MINIMUM ONCE A WEEK AND AFTER EVERY RAINFALL). MAINTENANCE SHALL BE PERFORMED AS NEEDED, AND SEDIMENT REMOVED WHEN "BULGES" DEVELOP IN SILT FENCE.

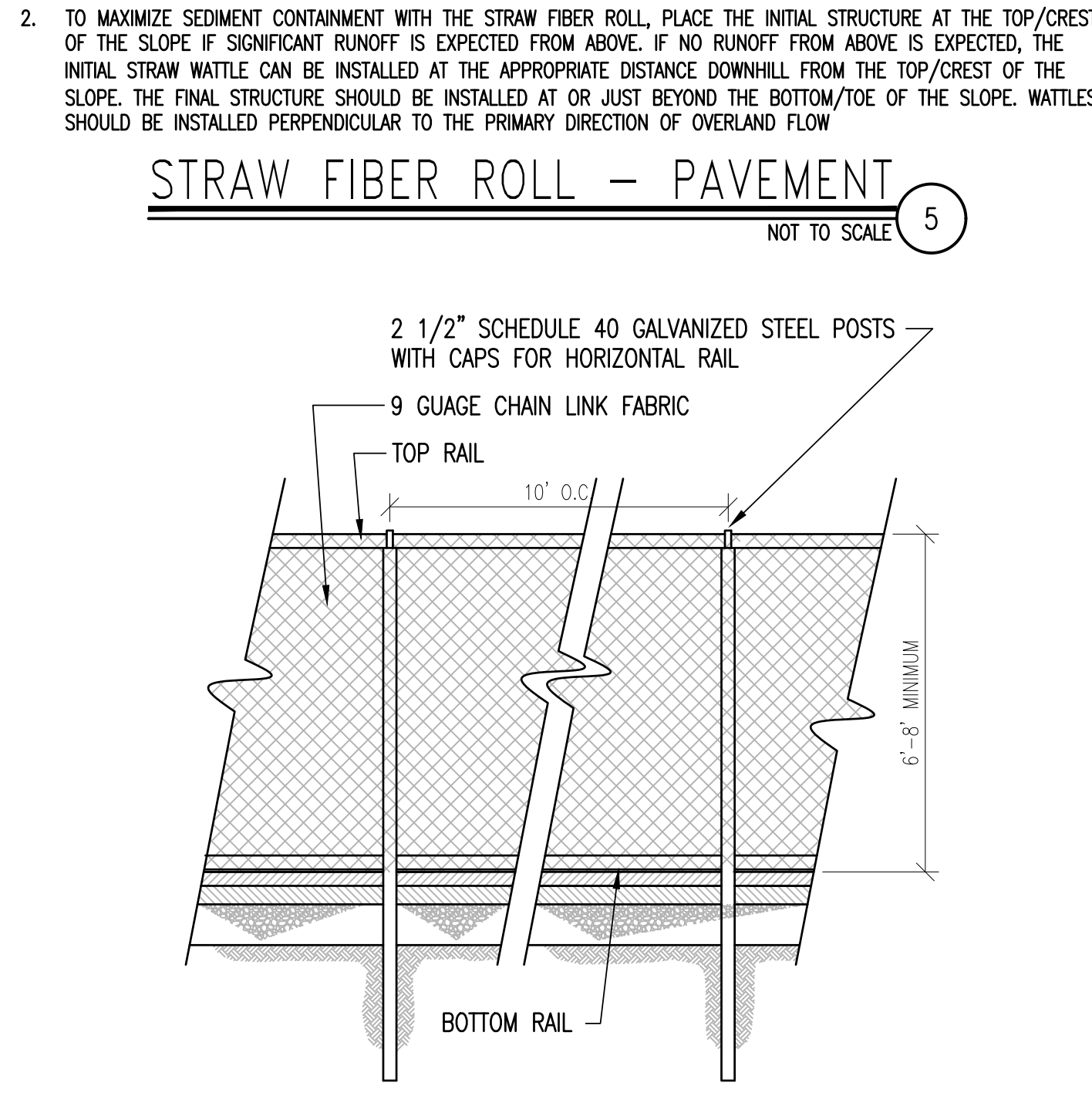

CONSTRUCTION FENCE DETAIL

NOT TO SCALE

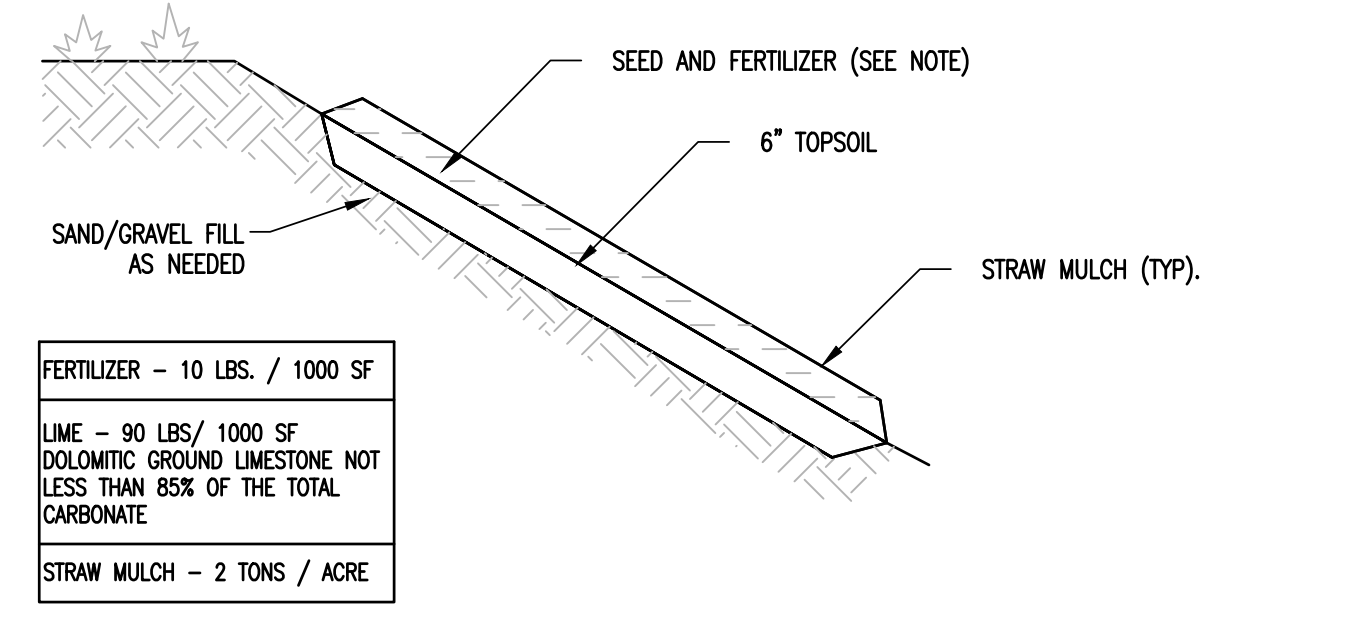

URBAN MIX GRASS SEED (FOR USE IN GRASSED LAWN AREAS AROUND BUILDINGS AND PARKING)		
% BY WEIGHT	LBS. LIVE SEED BY ACRE	TYPE OF SEED
37.5	45	CREeping RED FESCUE
31.3	37.5	KENTUCKY BLUEGRASS
31.3	37.5	WINTER HARDY, PERENNIAL RYE
100	120 LBS. LIVE SEED / ACRE	

- NOTES:**
- SEEDING AND MULCHING OF DISTURBED AREAS SHALL TAKE PLACE WITHIN 48 HOURS OF FINAL GRADING.
 - MULCH: HAY SHALL NOT BE USED. STRAW MULCH SHALL BE UTILIZED AND SHALL BE APPLIED AT A RATE OF 90-1,000 LBS/1,000 SF. MULCH SHALL NOT BE PLACED ON SLOPES OF GREATER THAN 3:1. SEED IMPREGNATED EROSION CONTROL NETTING SHALL BE USED IN ITS PLACE.
 - SEED: SEEDING SHALL OCCUR AFTER APRIL 15 AND PRIOR TO SEPTEMBER 15TH IN ORDER TO ESTABLISH A STAND OF GRASS PRIOR TO GROUND FREEZING. SEED SHALL BE IN ACCORDANCE WITH SEED SPECIFICATION ON THIS SHEET.
 - COVER SEED WITH 1/4 INCH SOIL UNLESS A HYDROSEEDER IS USED.
 - MULCH ANCHORING: SHALL BE APPLIED BY DEGRADABLE MULCH NETTING. USE WHEN SLOPES ARE GREATER THAN 10%.
 - TOPSOIL AND MULCHING NOT TO BE APPLIED IN AREAS OF TRAVEL WAYS.

SEEDED AND MULCHED AREAS DETAIL

NOT TO SCALE

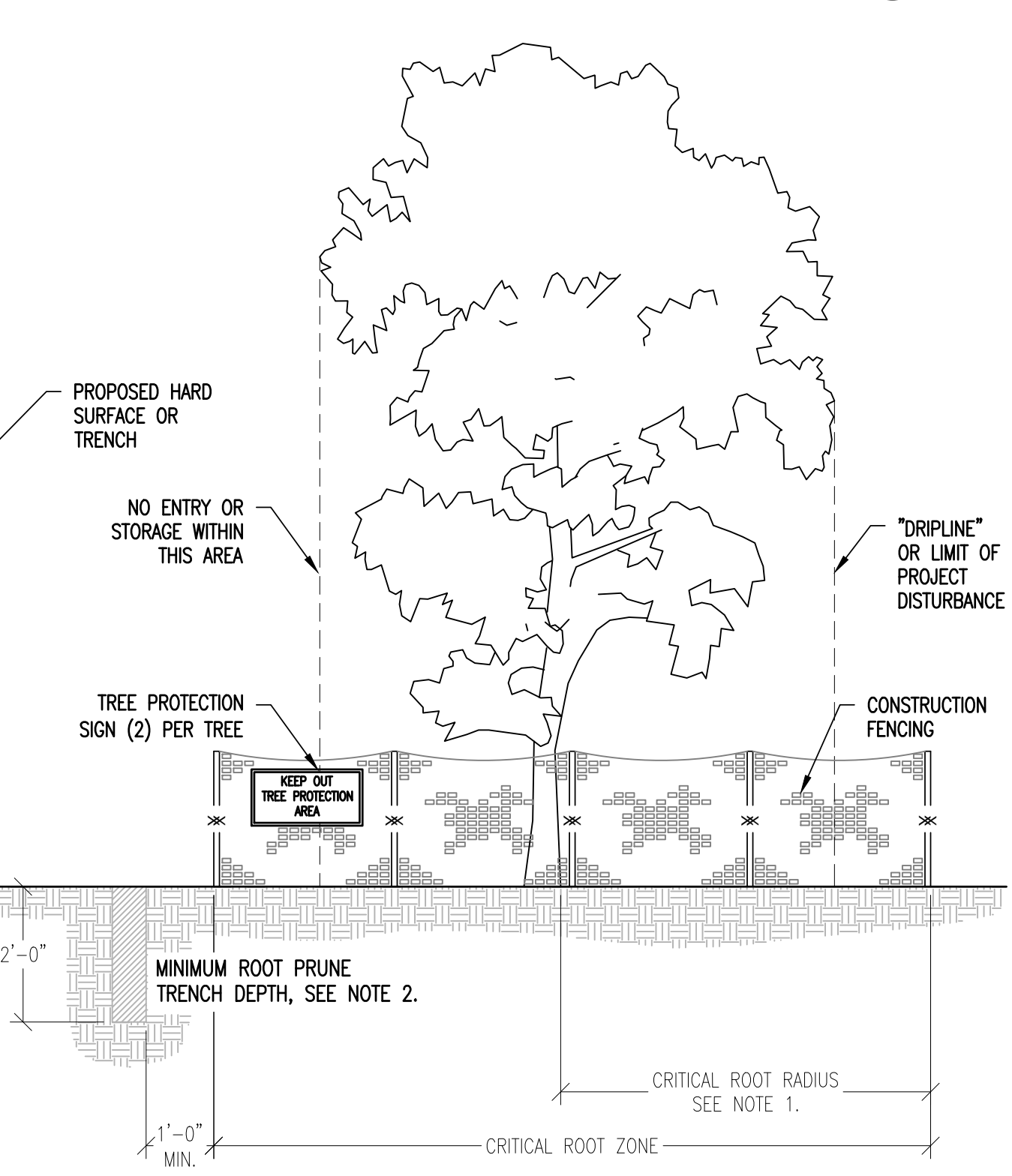

TREE PROTECTION DETAIL

NOT TO SCALE

- TREE PROTECTION NOTES:**
- TO CALCULATE THE CRITICAL ROOT RADIUS, ESTIMATE THE TREE'S HEIGHT AND MULTIPLY BY 40 PERCENT (0.40). THE RESULT IS THE APPROXIMATE DISTANCE FROM THE TREE TRUNK TO THE EDGE OF THE CONSTRUCTION FENCING.
 - FENCE SPECIMEN TREES AND GROUPS OF TREES WHERE ROOT LOSS WILL OCCUR, PRUNE ROOT ONE FOOT BEYOND THE CONSTRUCTION FENCE USING A VIBRATING KNIFE OR NARROW TRENCHER - ALWAYS WITH SHARP BLADES TO MAKE CLEAN CUTS. BACKFILL IMMEDIATELY AND COVER WITH 3 INCHES OF MULCH.
 - INSTALL SILT FENCE ON THE INTERIOR OF THE CONSTRUCTION FENCING TO KEEP SOIL FROM DISTURBED AREAS OUT OF THE ROOT ZONES OF TREES TO BE SAVED.
 - FERTILIZE, WATER, AERATE AND OTHERWISE AID TREE HEALTH.
 - COORDINATE THE FINAL LOCATION OF THE CONSTRUCTION FENCING AND ROOT PRUNING WITH THE OWNER.

GENERAL EROSION CONTROL NOTES

- THE CONTRACTOR SHALL DESIGNATE AN "ON-SITE EROSION CONTROL PLAN COORDINATOR" WHO WILL BE PRESENT ON-SITE FROM DAY-TO-DAY, AND SHALL BE RESPONSIBLE FOR ENSURING THAT THE EROSION CONTROL MEASURES REQUIRED BY THE EROSION CONTROL PLAN, DETAILS AND NOTES, ARE PROPERLY INSTALLED AND MAINTAINED. THE ON-SITE EROSION CONTROL PLAN COORDINATOR SHALL KEEP A WRITTEN RECORD OF INSPECTIONS AND MAINTENANCE OF EROSION CONTROL FEATURES. A COPY OF THESE PLANS AND INSPECTION/MAINTENANCE RECORDS SHALL BE KEPT ON-SITE AT ALL TIMES.
- THE CONTRACTOR SHALL NOTIFY THE TOWN OF BRISTOL DEPARTMENT OF PUBLIC WORKS DIVISION AT LEAST 24-HOURS PRIOR TO ANY EARTH DISTURBING ACTIVITIES AND SUBMIT THE NAME AND CONTACT INFORMATION (CELL PHONE AND EMAIL) OF THE ON-SITE EROSION CONTROL COORDINATOR FOR THE PROJECT. THE CONTRACTOR IS RESPONSIBLE FOR POSTING THE EROSION PREVENTION AND SEDIMENT CONTROL PLAN NOTICE IN A VISIBLE LOCATION AT ALL TIMES DURING EARTH DISTURBANCE.
- DISTURBANCE LIMITS ARE TO BE MARKED, AND THE FOLLOWING MANAGEMENT PRACTICES INSTALLED, PRIOR TO BEGINNING EARTHWORK IN ANY GIVEN AREA: SILT FENCE, CONSTRUCTION ENTRANCE, INLET PROTECTION & TREE PROTECTION FENCING.
- COMPLY WITH VERMONT STATE GENERAL CONSTRUCTION PERMIT CONDITIONS. ALL EROSION CONTROL MEASURES SHALL BE INSTALLED AND MAINTAINED IN ACCORDANCE WITH THE VERMONT DEC "THE VERMONT STANDARDS AND SPECIFICATIONS FOR EROSION PREVENTION & SEDIMENT CONTROL", DATED 2019.
- DURING THE NON-WINTER CONSTRUCTION SEASON, ALL DISTURBED AREAS ARE TO BE STABILIZED (TEMPORARY OR FINAL) WITHIN 14-DAYS OF INITIAL DISTURBANCE. AFTER THIS TIME, ANY DISTURBANCE WITHIN THIS WORK AREA MUST BE STABILIZED AT THE END OF EACH WORK DAY, WITH THE FOLLOWING EXCEPTIONS:
 - STABILIZATION IS NOT REQUIRED IF WORK IS TO CONTINUE IN THE AREA WITHIN 24 HOURS AND NO PRECIPITATION IS FORECAST DURING THAT PERIOD.
 - WORK IS OCCURRING WITHIN A SELF-CONTAINED EXCAVATION, 2- FEET OR MORE IN DEPTH.
- THE PERIOD BETWEEN NOVEMBER 1ST AND APRIL 15TH IS CONSIDERED THE "WINTER CONSTRUCTION PERIOD". IF SOILS WILL BE EXPOSED AFTER NOVEMBER 1ST, A PLAN FOR WINTER CONSTRUCTION MUST BE DEVELOPED BY THE CONTRACTOR AND SUBMITTED TO THE ENGINEER ON OR BEFORE OCTOBER 1ST. THE CONTRACTOR SHALL ENSURE SEDIMENT CONTROL IS INSTALLED PRIOR TO THE SOIL FREEZING. AN INSPECTION WILL BE REQUIRED IF THE PROJECT IS COMPLETED DURING THE WINTER MONTHS TO ENSURE THE SITE IS SECURED FOR THE REMAINDER OF THE SEASON.
- DURING THE WINTER CONSTRUCTION SEASON, ANY NEW DISTURBANCE MUST BE STABILIZED (TEMPORARY OR FINAL) AT THE END OF EACH WORK DAY, WITH THE FOLLOWING EXCEPTIONS:
 - STABILIZATION IS NOT REQUIRED IF WORK IS TO CONTINUE IN THE AREA WITHIN 24 HOURS AND NO PRECIPITATION IS FORECAST DURING THAT PERIOD.
 - WORK IS OCCURRING WITHIN A SELF-CONTAINED EXCAVATION, 2- FEET OR MORE IN DEPTH.
- IN NO CASE SHALL SOIL BE EXPOSED FOR MORE THAN 14 DAY WITHOUT BEING STABILIZED.
- ALL DISTURBED AREAS ARE TO BE PERMANENTLY STABILIZED WITHIN 48 HOURS OF FINAL GRADING.
- THE PERIMETER OF THE SITE AND ALL BMPs SHALL BE INSPECTED AT THE END OF EACH WORK DAY TO ENSURE SEDIMENT DOES NOT LEAVE THE SITE. IF SEDIMENT HAS TRAVELED BEYOND THE PROJECT LIMITS, IT SHALL BE RELOCATED IN AN UPGRADEMENT AREA ON SITE AT THE END OF EACH WORK DAY.
- ALL STABILIZATION INVOLVING SEEDING IS TO BE COMPLETED BY SEPTEMBER 15TH.
- THE CONTRACTOR SHALL BE RESPONSIBLE FOR DAILY INSPECTION OF THE ADJACENT ROADWAYS FOR OFF-SITE TRACKING OF SOIL MATERIALS. SOIL, STONE, AND DEBRIS FOUND LEAVING THE SITE ARE TO BE REMOVED (WHEN FOUND) BY SWEEPING AT THE END OF EACH CONSTRUCTION DAY, OR MORE FREQUENTLY WHEN NEEDED TO PREVENT IMPACTS TO ADJACENT ROADS AND SIDEWALKS.
- IF DEWATERING IS REQUIRED FOR CONSTRUCTION, THE CONTRACTOR MUST UTILIZE SEDIMENT FILTER BAGS (OR ALTERNATE APPROVED BY THE ENGINEER) TO PREVENT DISCHARGE OF SEDIMENT-LADEN WATER OFF SITE.
- EXCAVATED MATERIAL FROM EARTH EXCAVATION AND DITCH DIGGING SHALL BE PLACED ON-SITE IN A LOCATION TO BE APPROVED OF BY THE OWNER AND/OR THE ENGINEER OR USED FOR PROJECT FILL MATERIAL IF DETERMINED SUITABLE BY THE OWNER'S REPRESENTATIVE.
- STOCKPILED MATERIAL (TOPSOIL, BORROW, ETC.) SHALL HAVE SILT FENCE CONSTRUCTED AROUND THE PERIMETER. THE STOCKPILED MATERIAL SHALL BE SEEDED AND MULCHED AS SOON AS POSSIBLE TO PREVENT SOIL EROSION AND SEDIMENTATION OFF SITE. LOCATE STOCKPILES ON THE UPHILL SIDE OF DISTURBED AREAS, IF POSSIBLE. DURING WINDY CONDITIONS, STOCKPILED MATERIAL SHALL BE COVERED OR WATERED APPROPRIATELY TO PREVENT WIND EROSION.
- SLOPES GREATER THAN 3:1 SHALL HAVE EROSION CONTROL MATTING INSTALLED TO STABILIZE THE SLOPE AND REDUCE THE EROSION POTENTIAL. MATTING SHALL BE BIODEGRADABLE WITH A 12 MONTH LONGEVITY, 1500BS AS MANUFACTURED OR APPROVED EQUIVALENT. INSTALL MATTING OVER MULCHED SLOPES SO THAT MATTING IS IN CONTACT WITH THE SOIL AND MULCH. PIN MATTING WITH WIRE STAPLES 3 FEET O.C. TO ENSURE FULL BONDING WITH SOIL SURFACE. THE SLOPE SURFACES SHOULD BE LEFT SLIGHTLY ROUGHENED AND NOT SMOOTH. IF LARGE AMOUNTS OF OFFSITE WATER WILL DRAIN OVER THESE SLOPES, TEMPORARY DIVERSION SWALES SHALL BE INSTALLED UP SLOPE UNTIL THE SLOPE VEGETATION STABILIZES.
- THE OWNER SHALL BE NOTIFIED WHEN SITE WORK IS COMPLETED AND THE SITE IS STABILIZED.

WINTER EROSION CONTROL NOTES

- WINTER CONSTRUCTION PROCEDURES**
- DURING WINTER CONSTRUCTION, INSPECTIONS BY THE ON-SITE PLAN COORDINATOR SHALL OCCUR DAILY FOR ANY AREAS NOT FULLY STABILIZED, AND WEEKLY FOR THE ENTIRE SITE PRIOR TO ANY FORECASTED RAIN, THAW OR SPRING MELT WHEN TEMPORARY STABILIZATION IS IN PLACE.
 - IN AREAS TO BE STABILIZED BY VEGETATION, ALL SEEDING MUST BE COMPLETED BY SEPTEMBER 15 TO ALLOW GROWTH TO OCCUR PRIOR TO THE GROUND FREEZING. STABILIZATION OF ALL OTHER DISTURBED AREAS SHALL BE COMPLETED BY OCTOBER 15.
 - ENLARGED ACCESS POINTS, STABILIZED TO PROVIDE FOR SNOW STOCKPILING SHALL BE INSTALLED.
 - LIMITS OF DISTURBANCE SHALL BE MOVED OR REPLACED TO REFLECT BOUNDARY OF WINTER WORK.
 - SNOW WILL NOT BE PILED WITHIN 25 FEET OF PERIMETER CONTROLS (SUCH AS SILT FENCE) TO ALLOW FOR CLEARING AND MAINTENANCE. SNOW IS TO BE REMOVED FROM ALL STRUCTURAL EROSION PREVENTION AND SEDIMENTATION CONTROL MEASURES FOLLOWING EACH SIGNIFICANT SNOWFALL. NO SNOW STORAGE UP-GRADEMENT OF DISTURBANCE. NO SNOW DISPOSAL IN SEDIMENT PONDS/BASINS. IF NECESSARY, SNOW/ICE MUST BE REMOVED PRIOR TO STABILIZATION OF DISTURBED AREAS. ACCESS POINTS SHALL BE ENLARGED AND STABILIZED TO ALLOW FOR SNOW STOCKPILING.
 - IN AREAS OF DISTURBANCE WITHIN 100 FT OF A RECEIVING WATER, SILT FENCE SHALL BE REINFORCED OR ELSE REPLACED WITH PERIMETER DIKES, SWALES OR OTHER PRACTICES RESISTANT TO THE FORCES OF SNOW LOADS.
 - DRAINAGE STRUCTURES SHALL BE KEPT OPEN AND FREE OF SNOW AND ICE DAMS.
 - ALL EROSION PREVENTION AND SEDIMENT CONTROL MEASURES ARE TO BE IN PLACE BY OCTOBER 15, OR IF NOT POSSIBLE, THEN PRIOR TO GROUND FREEZE.
 - MULCH IS TO BE APPLIED AT THE END OF EACH WORKDAY TO ALL EXPOSED AREAS THAT HAVE NOT YET REACHED FINAL GRADE AT TWICE THE RATE INDICATED IN THE SEEDING AND MULCHING DETAIL FOR THE REGULAR CONSTRUCTION SEASON. MULCH SHALL BE TRACKED IN OR STABILIZED WITH NETTING.
 - TO ENSURE COVER OF DISTURBED SOIL IN ADVANCE OF A MELT EVENT, AREAS OF DISTURBED SOIL MUST BE STABILIZED AT THE END OF EACH WORK DAY, WITH THE FOLLOWING EXCEPTIONS:
 - IF NO PRECIPITATION WITHIN 24 HOURS IS FORECAST AND WORK WILL RESUME IN THE SAME DISTURBED AREA WITHIN 24 HOURS, DAILY STABILIZATION IS NOT NECESSARY.
 - DISTURBED AREAS THAT COLLECT AND RETAIN RUNOFF, SUCH AS HOUSE FOUNDATIONS OR OPEN UTILITY TRENCHES.
 - SNOW AND ICE SHALL BE REMOVED TO LESS THAN 1" THICKNESS PRIOR TO STABILIZATION.
 - STONE STABILIZATION, 10 TO 20 FT WIDE IN AREAS SUCH AS THE PERIMETER OF BUILDINGS UNDER CONSTRUCTION WHERE CONSTRUCTION VEHICLE TRAFFIC IS ANTICIPATED SHALL BE INSTALLED.

Stamp	
Date	
Description	
No.	
208 Pym Avenue, Suite 2A, Burlington, VT 05401 s 802-883-8225 1 South Street, PO Box 249 Bristol, Vermont, 05443 85 Mechanic Street, Suite E2-3, Lebanon, NH 03766 s 603-442-9333 414 Union Street, Schenectady, NY 12305 s 518-630-9814 www.engineeringventures.com	
Town of Bristol c/o Valerie Caples, Town Administrator 1 South Street, PO Box 249 Bristol, Vermont, 05443 802-453-2410 ext. 1	
Erosion Prevention & Sediment Control Details School Street Site Subsurface Infiltration Chamber Project Town of Bristol, Addison County, Vermont	
EV Project #	21230
Drawn By:	HKW
Checked By:	PB
Scale:	not to scale
Date:	02/10/2022
C3.2	

SECTION 31 0000
EARTHWORK

Part 1 GENERAL

1.01 SECTION INCLUDES

- A. Removal of topsoil and subsoil.
- B. Cutting, grading, filling, rough contouring, and compacting the site for site structures, roadways, parking lots, walks and equipment pads.
- C. Building perimeter and site structure backfilling to subgrade elevations.
- D. Excavating for building foundations, site structures, slabs-on-grade, paving, landscaping, and utilities.
- E. Site filling and backfilling.
- F. Fill under slabs-on-grade.
- G. Fill under paving.
- H. Fill for over-excavation.
- I. Consolidation and compaction as scheduled.

1.02 RELATED SECTIONS

- A. Section 31 05 16 Aggregates for Earthwork.
- B. Section 31 0516 Erosion and Sedimentation Control
- C. Section 32 1216 Asphalt Paving
- D. Section 32 1313 Concrete Paving
- E. For additional earthwork requirements near:
 - 1. Storm lines see 33 4000 Storm Drainage Utilities

1.03 REFERENCES

- A. AASHTO T180 - Moisture-Density Relations of Soils Using a 10 lb (4.54 kg) Rammer and an 18-in. (457 mm) Drop.
- B. ASTM C136 - Method for Sieve Analysis of Fine and Coarse Aggregates.
- C. ASTM D1557 - Test Methods for Moisture-Density Relations of Soils and Soil-Aggregate Mixtures Using 10 lb (4.54 Kg) Rammer and 18-inch (457 mm) Drop.
- D. ASTM D2487 - Classification of Soils for Engineering Purposes.
- E. ASTM D2922 - Test Methods for Density of Soil and Soil-Aggregate in Place by Nuclear Methods (Shallow Depth).
- F. ASTM D3017 - Test Methods for Moisture Content of Soil and Soil-Aggregate Mixtures.

1.04 QUALITY ASSURANCE

- A. Perform Work in accordance with State of Vermont, Agency of Transportation "Standard Specifications for Construction", dated 2018 (designated VAOT), and the latest revision of the Agency of Transportation "General Special Provisions".
- B. Testing and analysis of soil material in accordance with testing schedule at the end of this specification section.
- C. Testing and Analysis of Subsoil Material: Perform in accordance with ASTM D1557/ AASHTO T180 and ASTM D2922.
- D. Testing and Analysis of Topsoil Material: Perform in accordance with ASTM D2487.
- E. If tests indicate materials do not meet specified requirements, change material and retest.
- F. Provide materials of each type from same source throughout the Work.

1.05 PROJECT RECORD DOCUMENTS

- A. Submit under provisions of Section 10001.
- B. Accurately record actual locations of utilities remaining by horizontal dimensions, elevations or inverts, and slope gradients. Provide three ties to all bends and structures.

1.06 SUBMITTALS FOR REVIEW

- A. Section 10001 - Submittals: Procedures for submittals.
- B. Samples: Submit proposed location of use, name of imported materials source, sieve analysis and proctor results performed in accordance with ASTM/1557 for each type of fill. Soil testing to be provided by testing laboratory accepted by Engineer.
- C. Submit procedures for accomplishing dewatering work.

Part 2 PRODUCTS

2.01 MATERIALS

- A. Topsoil
 - 1. Excavated and reused material.
 - 2. Graded.
 - 3. Free of roots, rocks larger than 1 inch, subsoil, debris, weeds and foreign matter.
 - 4. Conforming to ASTM D2487 Group Symbol OH.
 - 5. The organic content, by dry weight, shall be no less than 3% nor more than 6%.
 - 6. Clay content between 15% and 25%.
 - 7. Sieve Designation

	Percent by weight passing square mesh sieves
a. 1 inch	100
b. 1/4 inch	65 – 100
c. #200	20 – 55
 - 8. The contractor may amend natural topsoil with approved materials and by approved methods to meet the above specifications.
 - 9. Frozen topsoil is not acceptable
 - B. Aggregate Materials: As specified in Section 31 0516 - Aggregates for Earthwork. Frozen aggregates are not acceptable.
 - C. Areas indicated as Subsoil Excavation, Common or Unclassified Fill or Borrow:
 - 1. Satisfactory materials for unclassified, common fill or borrow, the following are acceptable materials to be obtained and transported by the contractor from an offsite location:
 - a. Granular borrow material shall be obtained from approved sources, consisting of stone and sand reasonably free from loam, silt, clay and organic material and shall meet the requirements of the following table:

Sieve Designation:	Percent Mass Passing Square Mesh Sieve:
#4	20 to 100
#200	0 to 12

The maximum size of stone particles shall not exceed 6".
- D. Unsatisfactory Materials: Materials which do not comply with the requirements for satisfactory materials are unsatisfactory. Unsatisfactory materials also include man-made fills; trash; refuse; backfills from previous construction; and material classified as satisfactory which contains root and other organic matter or frozen material. Notify the engineer when encountering any contaminated materials.
- E. Type 'A' Fill shall be composed of one of the following types of aggregates obtained and transported by the contractor from an offsite location:
 - a. 3/4 inch Crushed Stone
 - b. 1 1/2" Crushed Stone
 - c. Course Crushed Gravel
 - d. Dense Graded Crushed Stone for Subbase.

2.02 ACCESSORIES

- A. Geotextile Fabric:
 - 1. Woven fabric for stability: Mirafi 500X or equivalent, as approved by Engineer.
 - 2. Non-Woven filter fabric for soil separation: Mirafi 140N or equivalent, as approved by Engineer.

- B. Buried Warning Identification tape
 - 1. All on-site existing and proposed subsurface utility piping and conduits shall be provided with metallic identification tape and ball markers.
 - 2. Provide metallic core or metallic-faced, acid- and alkali-resistant, polyethylene plastic warning tape manufactured specifically for warning and identification of buried utility lines. Manufacture tape with integral wires, foil backing, or other means of enabling detection by a metal detector when tape is buried up to 3 feet deep. Encase metallic element of the tape in a protective jacket or provide with other means of corrosion protection. Provide tape on rolls, 6 inches minimum width, 0.004 inches minimum thickness, 1500 pounds per square inch lengthwise and 1250 pounds per square inch crosswise color coded as specified below for the intended utility with warning and identification imprinted in bold black letters continuously over the entire tape length. Warning and identification to read, "CAUTION, BURIED (intended service) LINE BELOW" or similar wording. Provide permanent color and printing, unaffected by moisture or soil.
 - 3. Warning Tape Color Codes
 - a. Red: Electric
 - b. Yellow: Gas
 - c. Orange: Telephone and Other Communications
 - d. Blue: Water Systems
 - e. Green: Sewer Systems

Part 3 EXECUTION

3.01 EXAMINATION

- A. Verify that survey bench mark and intended elevations for the Work are as indicated.

3.02 STOCKPILING

- A. Stockpile materials offsite, unless otherwise agreed with Owner.
- B. Stockpile in sufficient quantities to meet Project schedule and requirements.
- C. Separate differing materials with dividers or stockpile apart to prevent mixing.
- D. Prevent intermixing of soil types or contamination.
- E. Direct surface water away from stockpile site to prevent erosion or deterioration of materials.

3.03 PREPARATION

- A. Identify required lines, levels, contours, and datum/benchmark locations.
- B. Stake and flag locations of known utilities.
- C. Locate, identify, and protect utilities that remain from damage.
- D. Notify utility company and contracting officer prior to removing or relocating utilities.
- E. Protect above and below grade utilities that remain.
- F. Protect plant life, lawns, and other features remaining as a portion of final landscaping.
- G. Protect bench marks, existing structures, signs, sidewalks, paving, and curbs from excavating equipment and vehicular traffic.

- H. Excavate topsoil from areas with proposed utility work, excavation, or proposed improvements. Stockpile in a segregated location.
- I. Remove deleterious material from site.

3.04 TOPSOIL EXCAVATION

- A. Excavate topsoil from areas with proposed utility work, excavation, re-landscaped, or re-graded, or other proposed improvements, without mixing with foreign materials.
- B. Do not excavate wet topsoil.
- C. Stockpile in area designated on site to depth not exceeding 12 feet and protect from erosion. Segregate topsoil from other soil, aggregates, materials, and debris.
- D. Remove deleterious material from site.
- E. Remove excess topsoil not intended for reuse, from site.
- F. Strip and stockpile organic topsoil material. Strip to a depth to remove all significant organic topsoil which shall be no less than 6 inches but not more than 12 inches.

3.05 SUBSOIL EXCAVATION

- A. Underpin adjacent structures which may be damaged by excavating work. Do not interfere with 45 degree bearing splay of foundations.
- B. Protect bottom of excavations and soil adjacent to and beneath foundation from freezing.
- C. Excavate subsoil from areas to be further excavated, re-landscaped, or re-graded.
- D. Excavate subsoil to accommodate building foundations, slabs-on-grade, paving and site structures, and construction operations.
- E. Control groundwater flowing toward or into excavations to prevent sloughing of excavation slopes and walls, boils, uplift and heave in the excavation and to eliminate interference with orderly progress of construction. Do not permit French drains, sumps, ditches or trenches within 3 feet of the foundation of any structure, except with specific written approval, and after specific contractual provisions for restoration of the foundation area have been made. While the excavation is open, maintain the water level continuously, at least 1 foot below the working level.
- F. Do not excavate wet subsoil. Grade top perimeter of excavating to prevent surface water from draining into excavation.
- G. When excavating through roots, perform work by hand and prune roots with appropriate sharp tools.
- H. Hand trim excavation. Remove loose matter.
- I. Remove lumped subsoil, boulders, and rock up to 1/3 cubic yard measured by volume.
- J. Notify Engineer and Project Manager of unexpected subsurface conditions and discontinue affected Work in area until notified to resume work.
- K. Stockpile in area designated on site to depth not exceeding 12 feet and protect from erosion. Remove subsoil from site not being reused.
- L. Stability: Replace damaged or displaced or over excavated subsoil to same requirements as specified for fill.
- M. Remove excess material not being used from site.

3.06 FILLING

- A. Install Work in accordance with State of Vermont, Agency of Transportation "Standard Specifications for Construction", dated 2018 (designated VAOT), and the latest revision of the Agency of Transportation "General Special Provisions".
- B. Compact native subgrade to density requirements for subsequent backfill materials.
- C. Scarify and proof roll subgrade surface to a depth of 4 inches to identify soft spots; fill and compact to density equal to or greater than requirements for subsequent fill material.

- D. Notify the Engineer prior to placing first lift of backfill in an area. Engineer may observe subgrade and request that the contractor proof-roll the excavation prior to allowing contractor to place fill.
- E. Cut out soft areas of native subgrade not capable of compaction in place. Backfill with granular backfill and compact to density equal to or greater than requirements for subsequent fill material.
- F. Verify sub-drainage, damp-proofing, or waterproofing installation has been inspected.
- G. Place geotextile fabric over subbase prior to placing next lift of fill in parking lots and paved areas. Where backfill is a granular, well draining material, adjacent to a material with fines (more than 6% passing the #200 sieve) the two materials shall be separated by geotextile.
- H. Backfill against supported foundation, do not backfill against unsupported foundation unless directed by structural engineer. Verify structural ability of unsupported walls to support imposed loads by the fill. If allowed, backfill simultaneously on each side of unsupported foundation walls until supports are in place.
- I. Employ a placement method that does not disturb or damage other work.
- J. Fill areas to proposed contours and elevations with unfrozen materials.
- K. Place fill material in continuous layers and compact in accordance with schedule at the end of this section. Systematically backfill to allow maximum time for natural settlement. Do not backfill over porous, wet, frozen or spongy subgrade surfaces.
- L. Maintain optimum moisture content of fill materials to attain required compaction density.
- M. Slope grade away from building minimum three percent for the first 10 feet, unless otherwise indicated on grading plans.
- N. Make grade changes gradual. Blend slope into level areas with minimum 10-foot transition, unless otherwise indicated on grading plans.
- O. Remove surplus fill materials from site.

3.07 UTILITY MARKERS AND BURIED WARNING AND IDENTIFICATION TAPE

- A. Provide and install metallic identification tape and/or tracer wire for all new utility lines or existing line where the contractor has disturbed the existing warning or metallic identification tape. Bury tape 12 inches below finished grade; under pavements and slabs, bury tape 6 inches below top of subgrade.

3.08 TOLERANCES

- A. Top Surface of Subgrade: Plus or minus 1/10 foot from required elevation.
- B. Top Surface of Backfilling under Paved Areas: Plus or minus 1/10 foot from required elevations.
- C. Top Surface of General Backfilling: Plus or minus 1 inch from required elevations.

3.09 STOCKPILE CLEANUP

- A. Remove stockpile, leave area in a clean and neat condition. Grade site surface to prevent free standing surface water.
- B. If a borrow area is indicated, leave area in a clean and neat condition. Grade site surface to prevent free standing surface water.

3.10 FIELD QUALITY CONTROL

- A. Contractor shall coordinate testing schedule with Owner and Engineer prior to beginning earthwork.
- B. Proof roll compacted fill surfaces under slabs-on-grade, paving, sidewalks, concrete pads.
- C. Testing: In accordance with ASTM D2922, ASTM D3017 and at the direction of the Owner.
- D. If tests indicate Work does not meet specified requirements, remove Work, replace and retest.

E. Frequency of Tests: See Schedule at end of section.

3.11 SCHEDULES

A. General Fill

1. Compact to 95% maximum density, modified proctor in the upper 3 feet.
2. Compact to 92% maximum density, modified proctor up to 3 feet below finished grade.
3. Maximum lifts of 12 inches loose measure before compaction.

END OF SECTION 31 0000 - EARTHWORK

SECTION 31 0516
AGGREGATES FOR EARTHWORK

Part 1 GENERAL

1.01 SECTION INCLUDES

- A. Aggregate materials.

1.02 RELATED SECTIONS

- A. Section 31 0000 Earthwork
- B. Section 31 2500 Erosion and Sedimentation Control
- C. Section 32 1216 Asphalt Paving
- D. Section 32 1313 Concrete Paving
- E. Section 33 4000 Storm Drainage Utilities
- F. Section 33 4923 Storm Chamber System

1.03 REFERENCES

- A. AASHTO - M147 - Materials for Aggregate and Soil-Aggregate.
- B. AASHTO T180 - Moisture-Density Relations of Soils Using a 10-pound (4.54 kg) Rammer and an 18-in. (457 mm) Drop.
- C. ASTM C136 - Method for Sieve Analysis of Fine and Coarse Aggregates.
- D. ASTM D1557 - Test Methods for Moisture-Density Relations of Soils and Soil-Aggregate Mixtures Using 10 pound (4.54 Kg) Rammer and 18-inch (457 mm) Drop.
- E. ASTM D2487 - Classification of Soils for Engineering Purposes.
- F. ASTM D2922 - Test Methods for Density of Soil and Soil-Aggregate in Place by Nuclear Methods (Shallow Depth).
- G. ASTM D3017 - Test Method for Moisture Content of Soil and Soil-Aggregate in Place by Nuclear Methods (Shallow Depth).
- H. ASTM D4318 - Test Method for Liquid Limit, Plastic Limit, and Plasticity Index of Soils.

1.04 SUBMITTALS FOR REVIEW

- A. Samples: Submit, in air-tight containers, 10 pound samples of each type of fill to testing laboratory.
- B. Sieve analysis for material and proposed use.

1.05 SUBMITTALS FOR INFORMATION

- A. Materials Source: Submit name of imported materials suppliers.

1.06 QUALITY ASSURANCE

- A. Perform Work in accordance with State of Vermont, Agency of Transportation "Standard Specifications for Construction", dated 2018 (designated VAOT), and the latest revision of the Agency of Transportation "General Special Provisions".

Part 2 PRODUCTS

2.01 AGGREGATE MATERIALS

A. Sand Borrow and Cushion (VTRANS 703.03A)

Sieve Designation	Percent by Weight Passing Sieve
2 inch	100
1-1/2 inch	90-100
1/2 inch	70-100
No. 4	60-100
No. 100	0-20
No. 200	0-8

B. Granular Borrow (VTRANS 703.04A)

Sieve Designation	Percent by Weight Passing Sieve
No. 4	20-100
No. 200	0-12

C. 3/8 Inch Stone (VTRANS 704.02A)

Sieve Designation	Percent by Weight Passing Sieve
1/2 inch	100
3/8 inch	85-100
No. 4	10 – 30
No. 8	0 - 10
No. 16	0 - 5

D. 3/4 Inch Stone (VTRANS 704.02B)

Sieve Designation	Percent by Weight Passing Sieve
1 inch	100
3/4 inch	90-100
3/8 inch	20 – 55
No. 4	0-10
No. 8	0-5

E. 1-1/2 Inch Stone (VTRANS 704.02C)

Sieve Designation	Percent by Weight Passing Sieve
2 inch	100
1-1/2 inch	95-100
3/4 inch	35-70
3/8 inch	10-30
No. 4	0-5

F. Gravel for Subbase (VTRANS 704.04A)

Sieve Designation	Percent by Weight Passing Sieve
No. 4	20-60
No. 100	0-12
No.200	0-6

G. Crushed Gravel, Coarse Graded (VTRANS 704.05A)

Sieve Designation	Percent by Weight Passing Sieve
4 inch	95-100
No. 4	25-50
No. 100	0-12
No. 200	0-6

H. Crushed Gravel, Fine Graded (VTRANS 704.05B)

Sieve Designation	Percent by Weight Passing Sieve
2 inch	100
1-1/2 inch	90-100
No. 4	30-60
No. 100	0-12
No. 200	0-6

I. Dense Graded Crushed Stone for Subbase (VTRANS 704.06A)

Sieve Designation	Percent by Weight Passing Sieve
3-1/2 inch	100
3 inch	90-100
2 inch	75-100
1 inch	50-80
1/2 inch	30-60
No. 4	15-40
No. 200	0-6

J. 1-1/2 inch Washed Crushed Stone (AASHTO M43 #4)

Sieve Designation	Percent by Weight Passing Sieve
2 inch	100
1-1/2 inch	90-100
1 inch	20-55
1/2 inch	0-15
3/8 inch	0-5

K. Granular Backfill for Structures (VTRANS 704.08A)

Sieve Designation	Percent by Weight Passing Sieve
3 inch	100
No. 4	45/75
No. 100	0-12
No. 200	0-6

L. Drainage Aggregate (VTRANS 704.16A)

Sieve Designation	Percent by Weight Passing Sieve
1 inch	100
3/4 inch	90-100
3/8 inch	20-55
No. 4	0-10
No. 8	0-5

M. Aggregate for EPSC (VTRANS 704.17A)

Sieve Designation	Percent by Weight Passing Sieve
6 inch	100
4 inch	80-100
3 inch	40-60
2 inch	0-20

N. Type I stone for stone fill (VTRANS 706.04, Type I)

The longest dimension of the stone shall vary from 1 inch to 12 inches, and at least 50 percent of the volume of the stone in place shall have a least dimension of four inches.

2.02 SOURCE QUALITY CONTROL

- A. Aggregate Material - Testing and Analysis: Perform in accordance with ASTM D1557.
- B. If tests indicate materials do not meet specified requirements, change material or material source and retest.
- C. Provide materials of each type from same source throughout the Work.

Part 3 EXECUTION

3.01 STOCKPILING

- A. Stockpile materials on site at locations designated by Owner.
- B. Stockpile in sufficient quantities to meet Project schedule and requirements.
- C. Separate differing materials with dividers or stockpile apart to prevent mixing.
- D. Direct surface water away from stockpile site so as to prevent erosion or deterioration of materials.

3.02 STOCKPILE CLEANUP

- A. Remove stockpile, leave area in a clean and neat condition. Grade site surface to prevent free standing surface water.
- B. If a borrow area is indicated, leave area in a clean and neat condition. Grade site surface to prevent free standing surface water.

END OF SECTION

SECTION 31 2500
EROSION AND SEDIMENT CONTROL

Part 1 GENERAL

1.01 SECTION INCLUDES

- A. Stabilization Practices.
- B. Structural Erosion and Sediment Practices.

1.02 RELATED SECTIONS

- A. Section 31 0000 Earthwork.
- B. Section 31 0516 Aggregates for Earthwork.
- C. Section 32 1216 Asphalt Paving.
- D. Section 33 4000 Storm Drainage Utilities.
- E. Section 33 4923 Storm Chamber System.

1.03 REFERENCES

- A. ASTM D2487 - Classification of Soils for Engineering Purposes.
- B. Vermont Construction General Permit 3-9020 (latest version).
- C. Vermont Standards and Specifications for Erosion Prevention and Sediment Control (VSS).

1.04 SUBMITTALS FOR REVIEW

- A. Samples: Submit sieve analyses and proctors for each type of fill. Soil testing to be provided by testing laboratory accepted by engineer.
- B. Product Data: Submit data on materials to be used.
- C. Manufacturer's Certificate: Certify Products meet or exceed specified requirements.
- D. Notification of On Site Plan Coordinator (OSPC)
- E. Storm Water Inspection Reports for General Permit Erosion and Sediment Controls

1.05 QUALITY ASSURANCE

- A. Perform Work in accordance with State of Vermont, Agency of Transportation "Standard Specifications for Construction", dated 2018 (designated VAOT), and the latest revision of the Agency of Transportation "General Special Provisions".
- B. Perform Work in accordance with the requirements of Vermont Construction General Permit 3-9020 (latest version), Vermont Standards for Erosion Prevention and Sediment Control, and the construction plans.
- C. Provide products and perform work in accordance with "The Vermont Standards & Specifications for Erosion Prevention & Sediment Control" published by The Vermont Department of Environmental Conservation, latest revision.

Part 2 PRODUCTS

2.01 MATERIALS

- A. Non-woven Filter Fabric: Mirafi 140N or equivalent.
- B. Woven Filter Fabric: Mirafi 500X or equivalent
- C. Erosion Control Matting: North American Green S75BN
- D. Mulch: Hay or straw which is air-dried and free of undesirable seeds and coarse materials shall be utilized.

- E. Woven wire fabric (14 gauge minimum) 6 inch x 6 inch
- F. Solid Oak Posts 2 inch x 2 inch x 30 inch Long

2.02 ACCESSORIES

- A. Materials shall be in accordance with State of Vermont, Agency of Transportation "Standard Specifications for Construction", dated 2018 (designated VAOT)

Part 3 EXECUTION

3.01 Perform Work in accordance with all applicable permits and all contract documents.

3.02 The Contractor shall function as the Principal Operator and employ and designate a person to serve as the On-Site Plan Coordinator as defined by the Construction General Permit. This person shall, as required by the permit:

- A. Meet all qualifications established for an On-Site Plan Coordinator.
- B. Perform all of the duties and record-keeping requirements as specified for the On-Site Plan Coordinator or "Permittee".
- C. Maintain all records required by the On-Site Plan Coordinator
- D. Make document immediately ready for inspection by the Owner and Engineer

3.03 Limits of disturbance (LODs) should be the first construction item implemented on a construction site. All disturbance areas bordering areas of existing vegetation should be demarcated with a barrier appropriate to the location.

- A. Chain-link Fence: used to prevent public access to active work areas.
- B. Construction Fence: for use where the proposed disturbance is limited in both scale and duration. Examples include areas where only sidewalk construction is planned.

3.04 MULCHING

- A. All disturbed surfaces shall be temporarily or permanently seeded and mulched within 7 days of disturbance.
- B. Seeding and mulching of disturbed areas shall take place within 48 hours of final grading.
- C. Mulch: Hay or straw which is Air-dried and free of undesirable seeds and coarse materials shall be utilized. Apply mulch at a rate of 90-100 pounds /1,000 square feet. Mulch shall cover more than 90% of the surface.
- D. Mulch shall not be placed on slopes of greater than 3:1. Seed impregnated erosion control netting shall be used in its place.
- E. Seed: seeding shall occur after May 15 and prior to September 15th in order to establish a stand of grass prior to ground freezing. Seed shall be in accordance with seed specification on the design drawings.
- F. Cover seed with 1/4-inch soil unless hydroseed is used.
- G. Mulch anchoring: Use a mulch anchoring tool (blunt, straight discs) which shall be pulled over the mulch. Use degradable mulch netting when slopes are greater than 10%. Install in accordance with Rolled Erosion Control product.
- H. Topsoil and mulching not to be applied in areas of travel ways.

3.05 EROSION CONTROL MATTING

- A. Install erosion control matting shall be installed in:
 - 1. All locations where it is indicated on the plans.
 - 2. In all locations where the proposed slope is greater than 10%.
 - 3. In all locations that require temporary stabilization where the slope is greater than 10%.
- B. Mats or blankets shall be installed vertically downslope.

- C. Mats or blankets shall be overlapped a minimum of 4 inches. The uphill blanket shall overlap the downhill blanket.
- D. Matting and blankets shall be anchored in accordance with the manufacturer's recommendations, with a minimum staple size and spacing as shown on the drawings.
- E. Slope surface shall be free of rocks, clods, sticks and grass. mats/ blankets shall have good soil contact in all areas.
- F. Apply permanent seeding before placing blankets.
- G. Apply matting and/blanket materials and staple to maintain direct contact with the soil. do not stretch.

3.06 SILT FENCE

- A. Construct silt fence in locations as shown on plans.
- B. Construct to the maximum extent possible parallel to the existing grade.
- C. Silt fence shall be pre-fabricated erosion control fence by Mirafi or equal, or constructed in place.
- D. Woven wire fence to be fastened securely to fence posts with wire ties or staples.
- E. Filter fabric to be fastened securely to woven wire fence ties spaced every 24 inches at top of mid section.
- F. When two sections of filter cloth adjoin each other, they shall be overlapped by 6 inches, wrapped together around a stake and stapled.
- G. Inspection shall be frequent (minimum once a week and after every rainfall). Maintenance shall be performed as needed, and sediment removed when "bulges" develop in silt fence
- H. The bottom 18 inches of fabric shall be buried a depth of 8 inches with backfill soil placed on top of the fabric.
- I. Posts shall be embedded a minimum of 18 inches.

3.07 CATCH BASIN INLET PROTECTION DEVICE

- A. Clear the area of all debris that will hinder excavation.
- B. Grade approach to the inlet uniformly around the basin.
- C. Weep holes shall be protected by gravel.
- D. Upon stabilization of contributing drainage area, seal weep holes, fill basin with stable soil to final grade, compact it properly and stabilize with permanent seeding.
- E. Gravel bags, grate guards, Filtrex or Sediguard inlet protection devices may be used. Submit product information to engineer for review prior to use. Install products in accordance with the manufacturer's instructions and the latest edition of the VT EPSC Standards and Specifications.

3.08 CONSTRUCTION ENTRANCE

- A. Install where located on plans and in all locations where vehicles leave the site.
- B. Install in accordance with the dimensions shown on the construction plans.
- C. Stone size: use type 1 stone-site/earthwork specifications. Place stone over Mirafi 500X Filter Fabric.
- D. Surface water: all surface water flowing or diverted toward construction entrance shall be piped across the entrance.
- E. Maintenance: the entrance shall be maintained in a condition which will prevent tracking or flowing of sediment onto public right-of-ways. this may require periodic top dressing with additional stone as conditions demand. repair and/or cleanout any measures used to trap sediment. all sediment spilled, dropped, washed, or tracked onto public right-of-ways must be removed immediately.
- F. Wheels shall be cleaned to remove mud prior to entrance onto public right-of-way. when washing is required, it shall be done on an area stabilized with stone which drains into an approved sediment trapping device.

3.09 DUST CONTROL

- A. Control dust for the duration of construction by the following methods, as necessary and if requested by the Town or Engineer:
1. Application of water
 2. Wet sweeping of surfaces, including adjacent road surfaces.
 3. Covering material stockpiles
 4. Ensuring that stone materials imported are clean, with little fine content.
 5. Stabilizing (temporary or permanent) disturbed areas when not under active construction.

END OF SECTION

SECTION 32 1216

ASPHALT PAVING

Part 1 GENERAL

1.01 SECTION INCLUDES

- A. Cutting and removal of all existing pavement as specified on the Design Drawings.
- B. Asphaltic concrete paving, wearing binder or base course. Surface sealer.
- C. Aggregate base course.
- D. Painting as required.

1.02 REFERENCES

- A. The State of Vermont, Agency of Transportation "Standard Specifications for Construction", dated 2018 (designated VAOT), and the latest revision of the Agency of Transportation "General Special Provisions."

1.03 QUALITY ASSURANCE

- A. All pavement work will be subject to quality control testing as specified by the VAOT.
- B. Obtain materials from same source throughout.

1.04 REGULATORY REQUIREMENTS

- A. Perform Work in accordance with the State of Vermont, Agency of Transportation "Standard Specifications for Construction", dated 2018 (designated VAOT), and the latest revision of the Agency of Transportation "General Special Provisions."

Part 2 PRODUCTS

2.01 MATERIALS

- A. Bituminous materials (including crack filler) shall comply with the Agency of Transportation "Standard Specification for Construction", dated 2018 (designated VAOT). The bituminous wearing course shall be Type III. The bituminous base course shall be Type II.
- B. Pavement markings shall be made from a normal type retro-reflectorized paint in standard colors (yellow or white) and per 646.06 VAOT. All colors are to be approved by the Owner.
- C. Signage, unless otherwise indicated, shall be in accordance with Section 675 VAOT.

Part 3 EXECUTION

3.01 COORDINATION OF WORK

- A. The Contractor shall coordinate all work to minimize impact on traffic and other work under this contract.

3.02 REMOVAL

- A. All pavement is to be saw-cut at all limits of removal, and recycled.

3.03 EXAMINATION

- A. Verify base conditions.
- B. Verify that existing subgrade is dry.
- C. Verify gradients and elevations of base are correct.

3.04 WEATHER LIMITATIONS

- A. Bituminous material shall be applied only when the ambient temperature is greater than 45 degrees Fahrenheit and the road surface and aggregate is dry.
- B. Bituminous material shall not be placed between November 30th and May 1st unless directed to do so by the Owner and Engineer.

3.05 PLACEMENT OF MATERIALS

- A. Install sub-base as shown on Construction Drawings, or to match existing adjacent sub-base.
- B. Coat existing saw-cut edge of pavement with emulsion. Apply in accordance with manufacturer's instructions.
- C. Placement of bituminous material shall be completed in accordance with the State of Vermont, Agency of Transportation "Standard Specifications for Construction", dated 2018 (designated VAOT).
- D. Placement of bituminous crack filler shall comply with Section 417 VAOT. Apply in accordance with manufacturer's instructions.
- E. The type and thickness of pavement shall be as shown on the Construction Drawings.
- F. Pavement markings shall be applied according to Section 646 VAOT. Pavement markings shall be configured as designated on the Design Drawings. A 4 inch wide white line shall be used for all pavement markings if not otherwise specified on the design drawings. Apply all marking in accordance with the manufacturer's instructions. Details not shown on the Plans shall be in conformance with the current edition of the MUTCD.
- G. Rolling of pavement courses shall be done with a 10-ton smooth wheeled roller. Where a roller will not fit, use a hand operated vibratory compactor.
- H. Signage, shall be installed in the location as indicated on the Pavement Marking and Signage plan in the Design Drawings. Install in accordance with Section 675 VAOT. Install signs perpendicular to the primary direction of vehicular travel unless indicated on the plans otherwise. Where the design plans show a sign co-located with a pipe bollard, the sign post shall be cast in concrete inside the pipe bollard.

3.06 TOLERANCES

- A. Flatness: Maximum variation of 1/4 inch measured with 10-foot straight edge.
- B. Scheduled Compacted Thickness: Within 1/4 inch.
- C. Variation from True Elevation: Within 1/2 inch.

3.07 FIELD QUALITY CONTROL

- A. Provide field inspection and testing per Owners direction.
- B. The Engineer will verify the acceptability of the pavement and markings in appearance and compliance with the requirements of the specification. Restored pavement that does not meet the specifications shall be corrected at no expense to the Owner.

END OF SECTION

**SECTION 32 1313
CONCRETE PAVING**

Part 1 GENERAL

1.01 SECTION INCLUDES

- A. Concrete Sidewalks
- B. Integral Curbs
- C. Pavements
- D. Exterior Pads

1.02 RELATED SECTIONS

- A. Section 31 0516 Aggregates for Earthwork.

1.03 REFERENCES

- A. The State of Vermont, Agency of Transportation "Standard Specifications for Construction", 2018 (designated VAOT), and the latest revision of the Agency of Transportation "General Special Provisions."

1.04 SUBMITTALS FOR REVIEW

- A. Product Data: For each type of product indicated
- B. Design Mixtures: For each concrete paving mixture. Include alternate design mixtures when characteristics of materials, Project conditions, weather, test results, or other circumstances warrant adjustments in accordance with ACI 301 and 318.
- C. Material certificates
 - 1. Cementitious materials
 - 2. Admixture
 - 3. Form materials and form-release agent
 - 4. Steel reinforcement and accessories
- D. Material Test Reports: For the following, from a qualified testing agency, indicating compliance with requirements:
 - 1. Aggregates: Include service record data indicating absence of deleterious expansion of concrete due to alkali aggregate reactivity.

1.05 QUALITY ASSURANCE

- A. Ready-Mix-Concrete Manufacturer Qualifications: A firm experienced in manufacturing ready-mixed concrete products and that complies with ASTM C 94/C 94M requirements for production facilities and equipment.
- B. ACI Publications: Comply with ACI 301 unless otherwise indicated.
- C. Perform work in accordance with The State of Vermont, Agency of Transportation "Standard Specifications for Construction", 2018 (designated VAOT), and the latest revision of the Agency of Transportation "General Special Provisions."

Part 2 PRODUCTS

2.01 MATERIALS

A. STEEL REINFORCEMENT

- 1. Retain first paragraph below if recycled content is required for LEED-NC or LEED-CS Credits MR 4.1 and MR 4.2. The USGBC allows a default value of 25 percent to be used for steel, without documentation; higher percentages can be claimed if they are supported by appropriate documentation.

2. Recycled Content: Provide steel reinforcement with an average recycled content of steel so postconsumer recycled content plus one-half of pre-consumer recycled content is not less than 70 percent.
 3. Reinforcing Bars: ASTM A 615/A 615M, Grade 60; deformed.
 4. Retain option in first paragraph below if required or if retaining wheel stops secured with galvanized dowels.
 5. Dowel Bars: ASTM A 615/A 615M, Grade 60 plain-steel bars; zinc coated (galvanized) after fabrication according to ASTM A 767/A 767M, Class I coating. Cut bars true to length with ends square and free of burrs.
 6. Bar Supports: Bolsters, chairs, spacers, and other devices for spacing, supporting, and fastening reinforcing bars, welded wire reinforcement, and dowels in place. Manufacture bar supports according to CRSI's "Manual of Standard Practice" from steel wire, plastic, or precast concrete of greater compressive strength than concrete specified.
- B. CONCRETE MATERIALS
1. Cementitious Material: Use the following cementitious materials, of same type, brand, and source throughout Project:
 - a. Portland Cement: ASTM C 150, Type I, gray.
 - b. Fly Ash: ASTM C 618, Class F.
 - c. Ground Granulated Blast-Furnace Slag: ASTM C 989, Grade 100 or 120.
 2. Normal-Weight Aggregates: ASTM C 33, graded.
 - a. Maximum Coarse-Aggregate Size: In accordance with ACI 301 and 318.
 - b. Fine Aggregate: Free of materials with deleterious reactivity to alkali in cement.
 3. Water: Non-potable and complying with ASTM C 94
 4. Air-Entraining Admixture: ASTM C 260.
 5. Chemical Admixtures: Admixtures certified by manufacturer to be compatible with other admixtures and to contain not more than 0.1 percent water-soluble chloride ions by mass of cementitious material.
- C. CURING MATERIALS
1. Moisture-Retaining Cover: ASTM C 171, polyethylene film or white burlap-polyethylene sheet.
 2. Evaporation Retarder: Waterborne, monomolecular, film forming, manufactured for application to fresh concrete.
- D. RELATED MATERIALS
1. Joint Fillers:
 - a. Traffic-bearing Pavements: ½ inch width, Deck-O-Foam by WR Meadows
 - b. All other concrete: ½ inch width, Ceramar by WR Meadows
 2. Joint Sealers
 - a. Traffic-bearing Pavements: Deck-O-Seal 125 by WR Meadows
 - b. All other concrete: Gardox by WR Meadows
 3. Sealers: Liqui-Hard by WR Meadows
- E. CONCRETE MIXTURES
1. Prepare design mixtures, proportioned according to ACI 301, with the following properties:
 - a. Use fly ash pozzolan or ground granulated blast-furnace slag as needed to reduce the total amount of portland cement, which would otherwise be used by 25 percent
 - b. Compressive Strength (28 Days): 4500 pounds per square inch.
 - c. Maximum Water-Cementitious Materials Ratio at Point of Placement: 0.45
 - d. Air Content: 5 percent plus or minus 1.0 percent.

2. Chemical Admixtures: Use admixtures according to manufacturer's written instructions.
- F. CONCRETE MIXING
1. Ready-Mixed Concrete: Measure, batch, and mix concrete materials and concrete according to ASTM C 94/C 94M. Furnish batch certificates for each batch discharged and used in the Work.

Part 3 EXECUTION

3.01 EXAMINATION AND PREPARATION

- A. Proof-roll prepared subbase surface below concrete paving to identify soft pockets and areas of excess yielding.
- B. Remove loose material from compacted subbase surface immediately before placing concrete.

3.02 EDGE FORMS AND SCREED CONSTRUCTION

- A. Set, brace, and secure edge forms, bulkheads, and intermediate screed guides to required lines, grades, and elevations. Install forms to allow continuous progress of work and so forms can remain in place at least 24 hours after concrete placement.
- B. Clean forms after each use and coat with form-release agent to ensure separation from concrete without damage.

3.03 STEEL REINFORCEMENT

- A. General: Comply with CRSI's "Manual of Standard Practice" for fabricating, placing, and supporting reinforcement.

3.04 JOINTS

- A. General: Form construction, isolation, and contraction joints and tool edges true to line, with faces perpendicular to surface plane of concrete. Construct transverse joints at right angles to centerline unless otherwise indicated.
- B. Construction Joints: Set construction joints at side and end terminations of paving and at locations where paving operations are stopped for more than one-half hour unless paving terminates at isolation joints.
- C. Isolation Joints: Form isolation joints of preformed joint-filler strips abutting concrete curbs, catch basins, manholes, inlets, structures, other fixed objects, and where indicated.
- D. Contraction Joints: Form weakened-plane contraction joints, sectioning concrete into areas as indicated. Construct contraction joints for a depth equal to at least one-fourth of the concrete thickness.
- E. Edging: After initial floating, tool edges of paving, gutters, curbs, and joints in concrete with an edging tool to a 3/8 inch radius. Repeat tooling of edges after applying surface finishes. Eliminate edging-tool marks on concrete surfaces.

3.05 CONCRETE PLACEMENT

- A. Moisten subbase to provide a uniform dampened condition at time concrete is placed.
- B. Comply with ACI 301 requirements for measuring, mixing, transporting, placing, and consolidating concrete.
- C. Deposit and spread concrete in a continuous operation between transverse joints. Do not push or drag concrete into place or use vibrators to move concrete into place.
- D. Screed paving surface with a straightedge and strike off.
- E. Commence initial floating using bull floats or darbies to impart an open-textured and uniform surface plane before excess moisture or bleed water appears on the surface. Do not further disturb concrete surfaces before beginning finishing operations or spreading surface treatments.

3.06 FLOAT FINISHING

- A. General: Do not add water to concrete surfaces during finishing operations.
- B. Initial floating operation is included in "Concrete Placement" Article.
- C. Float Finish: Begin the second floating operation when bleed-water sheen has disappeared and concrete surface has stiffened sufficiently to permit operations. Float surface with power-driven floats or by hand floating if area is small or inaccessible to power units. Finish surfaces to true planes. Cut down high spots and fill low spots. Refloat surface immediately to uniform granular texture.
 - 1. Retain one or more of three subparagraphs below or revise to suit Project.
 - 2. Medium-to-Fine-Textured Broom Finish: Draw a soft-bristle broom across float-finished concrete surface perpendicular to line of traffic to provide a uniform, fine-line texture.
 - 3. Medium-to-Coarse-Textured Broom Finish: Provide a coarse finish by striating float-finished concrete surface 1/16 to 1/8 inch deep with a stiff-bristled broom, perpendicular to line of traffic.

3.07 CONCRETE PROTECTION AND CURING

- A. General: Protect freshly placed concrete from premature drying and excessive cold or hot temperatures. Comply with ACI 306.1 for cold-weather protection.
- B. Evaporation Retarder: Apply evaporation retarder to concrete surfaces if hot, dry, or windy conditions cause moisture loss approaching 0.2 pounds per square foot x h before and during finishing operations. Apply according to manufacturer's written instructions after placing, screeding, and bull floating or darbying concrete but before float finishing.
- C. Begin curing after finishing concrete but not before free water has disappeared from concrete surface.
- D. Retain one or more options in paragraph below.
- E. Curing Methods: Cure concrete by moisture-retaining-cover curing.

3.08 PAVING TOLERANCES

- A. Comply with tolerances in ACI 117 and as follows:
 - 1. ACI 117 establishes few paving tolerances; those in subparagraphs below are based on ACI 330.1.
 - 2. Elevation: 1/4 inch.
 - 3. Thickness: Plus 3/8 inch, minus 1/4 inch.
 - 4. Surface: Gap below 10-foot- long, unlevelled straightedge not to exceed 1/2 inch.
 - 5. Joint Spacing: 3 inches.
 - 6. Contraction Joint Depth: Plus 1/4 inch, no minus.
 - 7. Joint Width: Plus 1/8 inch, no minus.

3.09 REPAIRS AND PROTECTION

- A. Remove and replace concrete paving that is broken, damaged, or defective or that does not comply with requirements in this Section. Remove work in complete sections from joint to joint unless otherwise approved by Engineer.
- B. Protect concrete paving from damage. Exclude traffic from paving for at least 14 days after placement. When construction traffic is permitted, maintain paving as clean as possible by removing surface stains and spillage of materials as they occur.
- C. Maintain concrete paving free of stains, discoloration, dirt, and other foreign material. Sweep paving not more than two days before date scheduled for Substantial Completion inspections.

END OF SECTION

SECTION 33 4000
STORM DRAINAGE UTILITIES

Part 1 GENERAL

1.01 SECTION INCLUDES

- A. Site storm sewerage drainage piping, fittings and accessories, manholes, catch basins, covers, and bedding.
- B. Trenching and backfill.

1.02 RELATED SECTIONS

- A. Section 31 0000 Earthwork.
- B. Section 31 0516 Aggregates for Earthwork.
- C. Section 33 4923 Storm Chamber System.

1.03 REFERENCES

- A. Refer to all current and relative ASTM sections.

1.04 SUBMITTALS FOR REVIEW

- A. Submit complete copies of all samples and shop drawings to the Owner and Engineer in pdf format for approval. All related items shall be submitted at the same time.
- B. Product Data: Provide data on pipe materials, pipe fittings, and accessories, manholes, covers, clean-outs and fittings.
- C. On all manufacturers' product cut sheets, specific items submitted for review shall be clearly indicated.
- D. Approval for shop drawings and samples must be received prior to purchasing equipment and products, and prior to starting work.
- E. In-place soil compaction tests and necessary supporting lab work.
- F. Gradation tests for bedding materials and subsurface materials.
- G. Concrete tests including compression tests, on-site slump, temperature, and air entrainment

1.05 SUBMITTALS FOR INFORMATION

- A. Manufacturer's Instructions: Indicate special procedures required to install Products specified.
- B. Certificates: Certify that products meet or exceed specified requirements.

1.06 SUBMITTALS AT PROJECT CLOSEOUT

- A. Record actual locations of pipes, connections, and invert elevations on record drawings.
- B. Identify and describe unexpected variations to subsoil conditions or discovery of uncharted utilities.

1.07 QUALITY ASSURANCE

- A. Perform Work in accordance with appropriate utility company, municipality and state codes.
- B. Protect all products and materials, before, during, and after installation.
- C. Where applicable, follow the manufacturer's recommended procedures for unloading, storage and installation of all products and materials.

1.08 EXISTING UTILITIES

- A. Location of utility installations and underground structures are shown as approximate on contract documents.

- B. Prior to submitting a proposal, the contractor shall fully review all drawings related to the existing site conditions, and shall become fully familiar with the nature and extent of the work to be done, and the materials required to complete the work.
- C. All utilities shall be located by the contractor prior to beginning construction. Report all discrepancies between that shown on the drawings and that found in the field to the engineer.
- D. Existing utilities shall be protected and supported during construction.
- E. All water, gas, cable, telephone, electric, sewer and other utilities found to interfere with the proposed construction shall be relocated in a manner acceptable to the engineer.

Part 2 PRODUCTS

2.01 STORM SEWER PIPE MATERIALS

- A. Plastic Pipe: ASTM D3034, SDR 35, Poly Vinyl Chloride (PVC) material; bell and spigot style rubber ring sealed gasket joint, ASTM F-758.
- B. Ductile Iron Pipe: Meeting AWWA/ANSI C150/A21.50-91
- C. High Density Polyethylene Pipe: AASHTO M 294, AASHTO M 252

2.02 ACCESSORIES

- A. Fittings: Same material as pipe molded or formed to suit pipe size and end design, in required tee, bends, elbows, clean-outs, reducers, traps and other configurations required.
- B. Flared-End-Sections shall be a precast reinforced concrete pipe flared-end-section meeting ASTM C76 with a transition to PVC pipe as shown on the drawings.
- C. Transition Couplings: as needed for connection to roof drain outlets.

2.03 CATCH BASINS, MANHOLES AND COVERS

- A. Manhole and Catch Basin sections: Reinforced precast 4000 psi concrete in accordance with ASTM C478 with gaskets in accordance with ASTM C923.
- B. Lid and frame: ASTM A48, Class 30B, 24 inch opening, cast iron construction, machined flat bearing surface, removable lid with H20 rating. Lid and frame shall be placed off-center over manhole steps. Catch basin lids to be grated.
- C. Manhole steps: Polyethylene (PE) coated ½ inch diameter steel rungs. Steps shall be installed at 12 inches on center.
- D. All pipe penetrations shall be pre-cast or cleanly cored, and shall be clear of all joints by a minimum of 6 inches of full wall thickness.
- E. Riser sections shall be precast concrete unless otherwise approved by the Engineer.

2.04 CLEAN-OUTS

- A. Pipe and Cover: Vertical pipe shall be PVC SDR 35. Clean-out frame and cover shall be Lebaron No. LA0910 or approved equal, and labeled "CLEANOUT".

2.05 BEDDING AND COVER MATERIALS

- A. Bedding: Fill Type meeting the requirements of Sand Blanket, Sand Fill, or Sand Borrow.
- B. Cover: Fill Type meeting the requirements of Sand Blanket, Sand Fill, or Sand Borrow or Common Fill as required by the drawings at various depths of cover.

Part 3 EXECUTION

3.01 EXAMINATION

- A. Verify existing conditions.
- B. Verify that building connections and municipal utility storm sewer size, location, and invert are as indicated.

- C. Notify local municipalities 48 hours prior to commencing any storm sewer work. Specify which services are likely to be interrupted and the estimated schedule of work.

3.02 TRENCHING AND BEDDING

A. Preparation

1. Identify required lines, levels, contours, and datum locations.
2. Protect plant life, lawns, rock outcropping and other features remaining as a portion of final landscaping.
3. Protect bench marks, existing structures, fences, sidewalks, paving, and curbs from excavating equipment and vehicular traffic.
4. Maintain and protect above and below grade utilities which are to remain.
5. Cut out soft areas of subgrade not capable of compaction in place. Backfill with appropriate Fill Type meeting the requirements of the Earthwork Section 310000 and compact to density equal to or greater than requirements for subsequent backfill material.

B. Excavating

1. Excavate subsoil required for utilities to municipal utilities.
2. Cut trenches sufficiently wide to enable installation and allow inspection. Remove water or materials that interfere with Work.
3. Do not interfere with 45 degree bearing splay of foundations.
4. Excavation shall be 6 inches below pipe inverts to accommodate the bedding material. Correct areas over Hand trim excavation. Hand trim for bell and spigot pipe joints. Remove loose matter.
5. Stockpile excavated material in area designated on site and remove excess material not being used, from site.

- C. Place bedding material at trench bottom, level fill materials in one continuous layer not exceeding 8 inches compacted depth; compact to 95 percent of standard optimum density.

- D. Backfill around sides and to top of pipe with cover fill, tamp in place and compact to 95 percent of modified optimum density.

- E. Maintain optimum moisture content of bedding material to attain required compaction density.

3.03 INSTALLATION – PIPE

- A. During loading, transportation and unloading, take care to prevent damage to pipes and fittings. Examine all pipes and fittings before laying, no damaged piece shall be installed. Take care to keep inside of pipe clean.

- B. Coordinate the Work with termination of foundation and roof drain connections outside building, connection to municipal storm sewer utility service, and trenching.

- C. Maintain separation from other piping in accordance with VT DEC requirements.

- D. Install pipe, fittings, and accessories in accordance with manufacturer's instructions.

- E. Lay pipe straight and to slope gradients noted on drawings; with maximum variation from true slope of 1:1000.

- F. Pipe shall be laid with bell ends facing upslope.

- G. Where pipe is laid on a slope of 5 percent or more, the laying shall start at the low end and proceed uphill, with the bell ends upgrade.

- H. A watertight plug shall be placed in the open ends of installed pipe when pipe laying is not in progress.

- I. If any defective piping or fitting is discovered after it has been laid, it shall be removed and replaced at the contractor's expense.

3.04 BACKFILLING

- A. Backfill trenches to contours and elevations with unfrozen fill materials.

- B. Systematically backfill to allow maximum time for natural settlement. Do not backfill over porous, wet, frozen, or spongy subgrade surfaces.

- C. Refer to applicable details for backfill material type and compaction requirements.

- D. Maintain optimum moisture content of fill materials to attain required compaction density.

- E. Remove surplus fill materials from site.
- F. Leave fill material stockpile areas completely free of excess fill materials.

3.05 INSTALLATION - MANHOLES, CATCH BASINS AND CLEAN-OUTS

- A. Form bottom of excavation clean and smooth to correct elevation. Provide 12-inch crushed stone base.
- B. Form and place cast-in-place concrete base pad, with provision for storm sewer pipe end sections.
- C. Level top surface of base pad; sleeve concrete shaft sections to receive storm sewer pipe sections.
- D. Establish elevations and pipe inverts for inlets and outlets as indicated.
- E. Mount lid and frame level in grout, secured to top cone section to elevation indicated.

3.06 RESTORATION OF THE SURROUNDING SITE

- A. At the completion of storm sewer line installation, the surrounding site shall be restored according to drawings (if shown), otherwise to a condition equal to that existing before the beginning of the work.

END OF SECTION

SECTION 33 4923
SPECIAL PROVISION STORM CHAMBER SYSTEM

Part 1 GENERAL

1.01 SECTION INCLUDES

- A. Corrugated polyethylene infiltration chambers, end caps, pipe connections, drainage aggregate, geotextile, inspection ports and related items as depicted on project plans.

1.02 RELATED SECTIONS

- A. Section 31 0000 Earthwork.
- B. Section 31 0516 Aggregates for Earthwork.
- C. Section 33 4000 Storm Drainage Utilities.

1.03 REFERENCES

- A. Refer to all current and relative ASTM sections.

1.04 SUBMITTALS FOR REVIEW

- A. Prior to commencement of work, the Contractor shall submit shop drawings to the Engineer showing relevant layout and construction details, along with volume estimates.

1.05 SUBMITTALS FOR INFORMATION

- A. Manufacturer's Instructions: Indicate special procedures required to install Products specified.
- B. Certificates: Certify that products meet or exceed specified requirements.

1.06 SUBMITTALS AT PROJECT CLOSEOUT

- A. Record actual locations of system, and invert elevations on record drawings.
- B. Identify and describe unexpected variations to subsoil conditions or discovery of uncharted utilities.

1.07 QUALITY ASSURANCE

- A. Perform Work in accordance with appropriate utility company, municipality and state codes.
- B. Protect all products and materials, before, during, and after installation.
- C. Follow the manufacturer's recommended procedures for unloading, storage and installation of all products and materials.

Part 2 PRODUCTS

2.01 POLYETHYLENE CHAMBERS

- A. Chambers to be constructed of virgin polyethylene and rated to support HS-20 loading when properly installed. Each chamber section is to measure 43.8" long, 100" wide, 60" high, and provide a minimum installed storage of 166.3 cubic feet.

2.02 GEOTEXTILE FABRIC

- A. Non Woven: Geotex 601T, Mirafi 180N or approved equal.
- B. Woven: Geotex 315WT, Mirafi 600X or approved equal.

Part 3 EXECUTION

3.01 INSTALLATION

- A. Excavate bed and prepare subgrade per engineer's plans and manufacturer's requirements.
- B. Place non-woven geotextile over prepared soils and up excavation walls.
- C. Place clean, crushed, angular stone foundation 12" (300 mm) min. Compact to achieve a flat surface.
- D. Install manifolds and lay out woven scour geo textile at inlet rows [min. 10.3 ft (3.2 m)] at each inlet end cap. Place a continuous piece (no seams, double layer) along entire length of Isolator® Row.
- E. Install chambers by overlapping end corrugations. Maintain a minimum of 9" spacing between rows. Install end caps at both ends of each row. Neatly cut end caps to closely fit pipe connections.
- F. Evenly backfill to avoid displacement and/or unequal support of chambers. Fully extend stone backfill horizontally to edges of excavation. Continue stone backfill and compaction as indicated in the contract documents.

END OF SECTION