

Bristol Town Administrator

From: Vermont Local Roads Program <VT-LOCALROADS@LISTSERV.VERMONTLOCALROADS.ORG> on behalf of AOT - Vermont Local Roads <AOT.VermontLocalRoads@VERMONT.GOV>
Sent: Friday, October 21, 2022 10:39 AM
To: VT-LOCALROADS@LISTSERV.VERMONTLOCALROADS.ORG
Subject: DEC Press Release - Stormwater Permit Threshold Enacted in 2019 Took Effect in July 2022

Stormwater Permit Threshold Enacted in 2019 Took Effect in July 2022

FOR IMMEDIATE RELEASE

Press Release

Contact:

Terry Purcell, Operational Section Supervisor
Stormwater Program, Department of Environmental Conservation
802-490-6166, Terry.Purcell@vermont.gov

Montpelier, VT, October 18, 2022 – On December 1, 2020, the Vermont Department of Environmental Conservation (DEC) issued the [Stormwater General Permit 3-9050](#) (bit.ly/SW-3-9050) to help protect Vermont waterways. The permit regulates stormwater discharges or runoff from impervious surfaces (any hard or solid surfaces like roofs, roads, and parking lots where water runs off instead of soaks in). Within the 2020 permit, the DEC listed activities that require permit coverage, including the new development or redevelopment of ½ acre or more of impervious surface starting July 1, 2022.

“Stormwater runoff not only erodes our soils but also carries sediment, phosphorus, and other pollutants into our waterways,” said DEC Commissioner John Beling. “Issuing this permit is a key part of the Vermont Clean Water Act of 2015. Vermont needs to reduce stormwater runoff from commercial, industrial, residential, and institutional properties to meet clean water goals.”

Property owners must apply for General Permit 3-9050 for stormwater discharges or runoff from the following types of projects:

- **A new development with a ½ acre or more of impervious surface. New development is construction of impervious surface on a tract or tracts of land where no impervious surface previously existed. ***
- **A redevelopment of an existing impervious surface if the redeveloped part of the existing impervious surface totals a ½ acre or more. ***
- An expansion of an existing impervious surface, such that the resulting impervious surface totals 1 acre or more.
- Projects with impervious surfaces of 3 or more acres that meet the definition of an “impervious surface of three or more acres” in General Permit 3-9050 and as described in Subpart 1.3(D) of the General Permit.
- Projects that were previously permitted for discharges of stormwater runoff and must renew permit coverage due to expiration of the permit.

* Projects are impacted by the lowered ½ acre threshold that took effect on July 1, 2022.

Projects starting new development or redevelopment of ½ acre or more acres of impervious surface are not subject to the lowered ½ acre threshold if one of the transition exemptions in General Permit 3-9050(1.5)(F) is applicable. The previous threshold of 1 acre or more of impervious surface for new development and redevelopment applies for these projects.

In 2019 and 2020, the DEC offered opportunities for the public to comment on the ½ acre threshold. The ½ acre threshold can be found in the [Chapter 22 Stormwater Permitting Rule \(bit.ly/VT-SW-Rule\)](https://www.vermont.gov/doc/dec/2019-03-15-chapter-22-stormwater-permitting-rule) since it's effective date of March 15, 2019, and in the General Permit 3-9050 since its effective date of December 1, 2020.

“With the ½ acre threshold for permit coverage that took effect in July 2022, Vermont can better manage stormwater, improve water quality, protect natural resources, and safeguard human health,” said Beling.

Licensed professional engineers must prepare all permit applications. To find an engineer, property owners and members of the public may use a [list of firms \(bit.ly/SW-firms\)](https://www.vermont.gov/doc/dec/2022-07-01-list-of-firms) that have sent permit applications in the past.

For more information, read about the [½ acre threshold and transition exemptions \(bit.ly/VT-half-acre\)](https://www.vermont.gov/doc/dec/2022-07-01-1-2-acre-threshold-and-transition-exemptions). The [Stormwater Management Program \(bit.ly/VT-SMP\)](https://www.vermont.gov/doc/dec/2022-07-01-stormwater-management-program) oversees regulations and offers technical assistance for stormwater management. If Terry Purcell is not available, contact Michael Sadler at 802-490-6159 or Michael.Sadler@vermont.gov.

The Vermont Clean Water Act of 2015 assures consistency with applicable requirements of the federal Clean Water Act of 1972. Coincidentally, today is the 50th anniversary of the federal law and this action is representative of how Vermont continues to uphold and work towards its shared vision of reducing pollution that enters rivers and lakes from their source.

###

The Department of Environmental Conservation is responsible for protecting Vermont's natural resources and safeguarding human health for the benefit of this and future generations. Visit dec.vermont.gov and follow the Department of Environmental Conservation on [Facebook](#) and [Instagram](#).



Stormwater runoff not only erodes soils but also carries pollutants into Vermont's waterways.

JULY 2022 HALF ACRE PROJECT THRESHOLD CHANGES

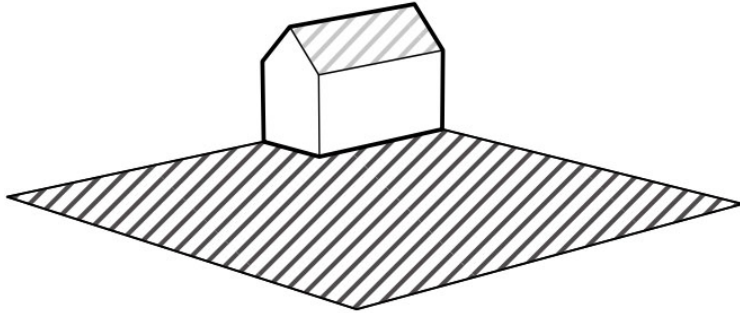

Jurisdictional Trigger Prior to 7.1.2022 - 1.0 Acre

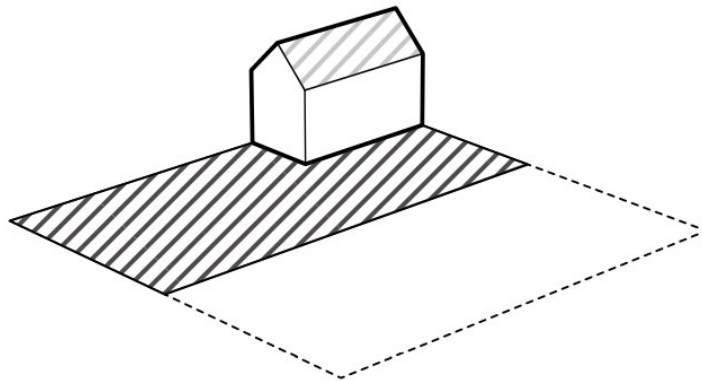
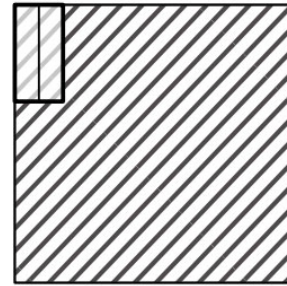

Jurisdictional Trigger After 7.1.2022 - 0.5 Acre

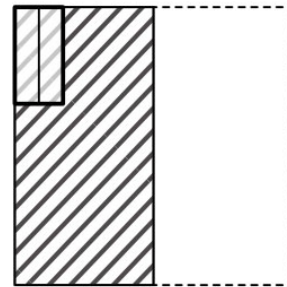

 Impervious Surface

The threshold for permit coverage changed from 1 acre to a ½ acre of impervious surface for new development and redevelopment on July 1, 2022.

Read the [press release online](#).

To unsubscribe from the VT-LOCALROADS list, click the following link:
<http://listserv.vermontlocalroads.org/scripts/wa-VLRDS.exe?SUBED1=VT-LOCALROADS&A=1>