

- NOTES**
- UTILITIES SHOWN DO NOT PURPORT TO CONSTITUTE OR REPRESENT ALL UTILITIES LOCATED UPON OR ADJACENT TO THE SURVEYED PREMISES. EXISTING UTILITY LOCATIONS ARE APPROXIMATE ONLY. THE CONTRACTOR SHALL FIELD VERIFY ALL UTILITY CONFLICTS. ALL DISCREPANCIES SHALL BE REPORTED TO THE ENGINEER. THE CONTRACTOR SHALL CONTACT DIG SAFE (888-344-7233) PRIOR TO ANY CONSTRUCTION.
 - THE PROPERTY LINES, EASEMENTS, AND OTHER REAL PROPERTY DESCRIPTIONS PROVIDED IN THIS PERMIT APPLICATION ARE FOR PLANNING PURPOSES ONLY. THEY DO NOT DEFINE LEGAL RIGHTS OR MEET LEGAL REQUIREMENTS FOR A LAND SURVEY AS DESCRIBED IN 26V.S.A. §2502(4), AND SHALL NOT BE USED IN LIEU OF A SURVEY AS THE BASIS OF ANY LAND TRANSFER OR ESTABLISHMENT OF ANY PROPERTY RIGHT.
 - EXISTING WATER LINE LOCATIONS SHALL BE FIELD VERIFIED BY THE CONTRACTOR.

Isolation Distances

Item	Horizontal Distance (feet)		
	Disposal field	Septic tank	Sewer
Drilled well	50	50	50
Lake and pond impoundment - standing water	50	25	25
River, streams	50	25	10
Drainage swales, roadway ditches	25	-	-
Main or municipal water lines	50	50	b*
Service water lines	25	25	b*
Roadways, driveways, parking lots	10	5	-
Top of embankment, or slope greater than 30%	25	10	-
Property line	25	10	10
Other disposal field or replacement area	10	10	-
Foundation, footing drains, curtain drains	35	10	-
Suction water line	100	50	50

* a) see presumptive isolation zone on plan
 * b) see Vermont Water Supply Rule

Survey and alignment information obtained from a digital file provided by LaRose Surveys, PC. VTM Engineering, PLC assumes no responsibility for the accuracy or completeness of this information.

SITE PLAN
 SCALE: 1" = 30'

VERMONT
 DEPARTMENT OF ENVIRONMENTAL CONSERVATION
 Drinking Water & Groundwater Protection Division
 THIS IS SUBJECT TO PROVISIONS OR CONDITIONS LISTED IN PERMIT
 Permit #: **WW-9-1537-4**
 Date: **04/25/2024**

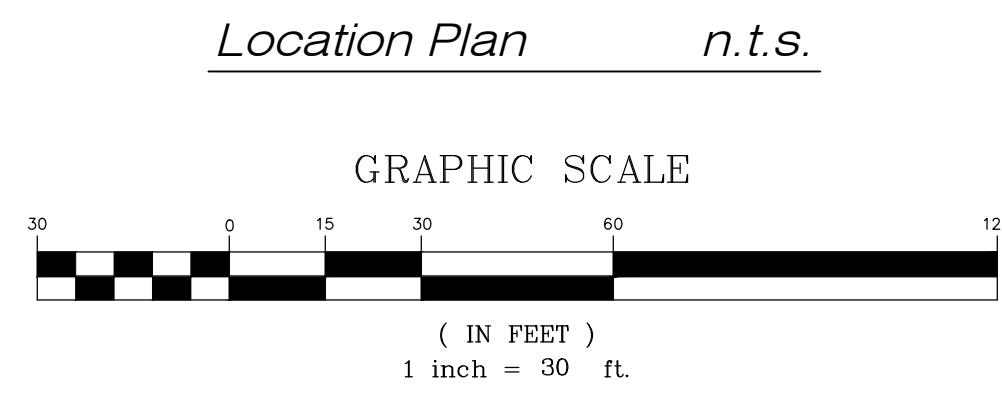

REV.	DATE	DESCRIPTION	BY

VTM ENGINEERING, PLC
 2941 SHELburnE FALLS ROAD
 BRISTOL, VT 05401
 (802) 233-7531



WATER LINE DESIGN

PROPOSED WATER DISTRIBUTION SYSTEM SITE PLAN
 PLANK ROAD & JAY DRIVE
 BRISTOL, VT
 HEFFERNAN REVOCABLE TRUST
 BRISTOL, VT 05443

DESIGNED	SP	DATE	2/12/2024
DRAWN	PM	SCALE	AS SHOWN
CHECKED	SP	DATE	2/12/2024
PROJECT NO.	24.1		
DRAWING NO.	C1.0		

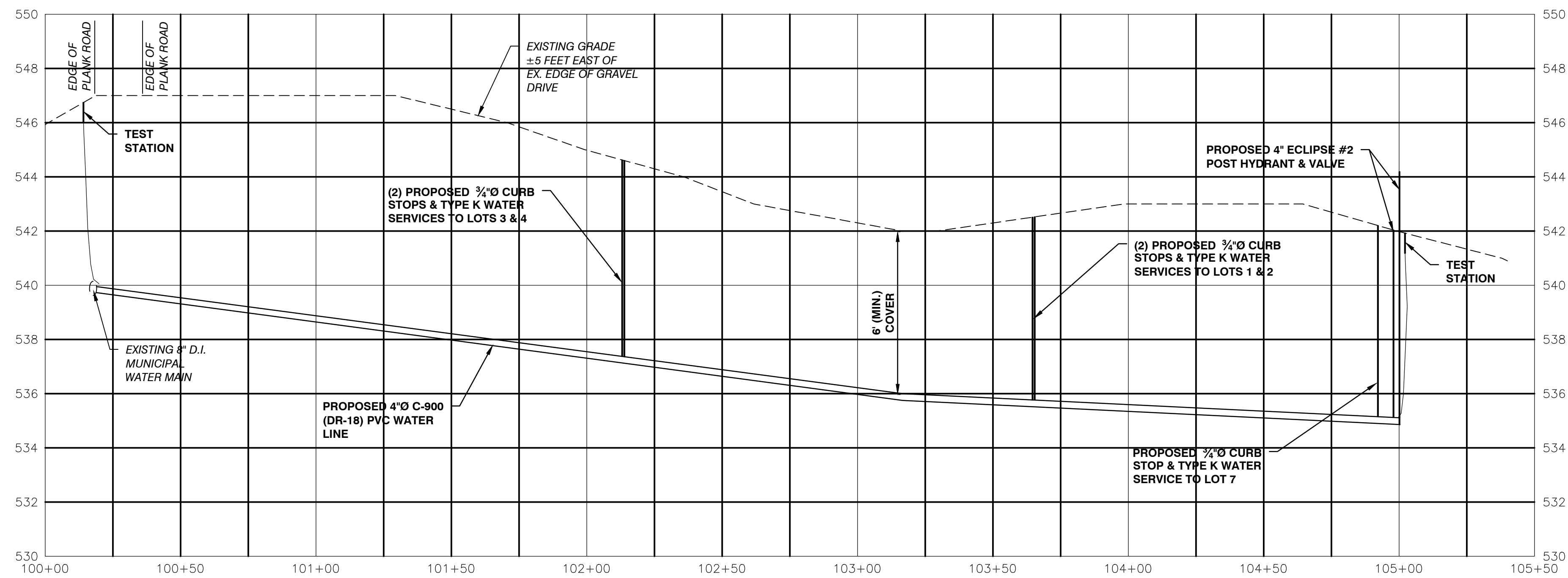

WATER LINE PROFILE

HORIZONTAL SCALE: 1" = 30'
VERTICAL SCALE: 1" = 3'

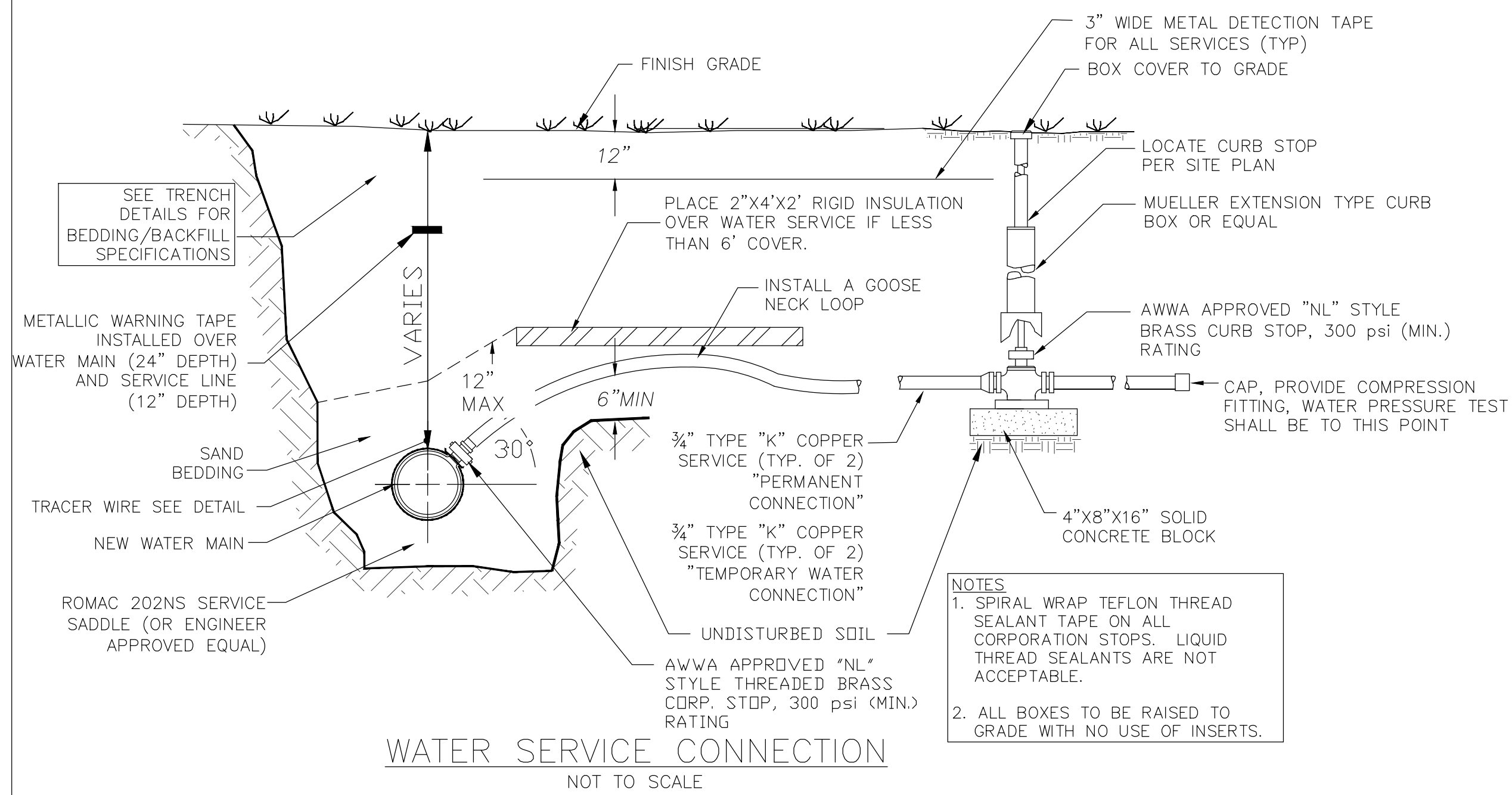

WATER SERVICE CONNECTION
NOT TO SCALE

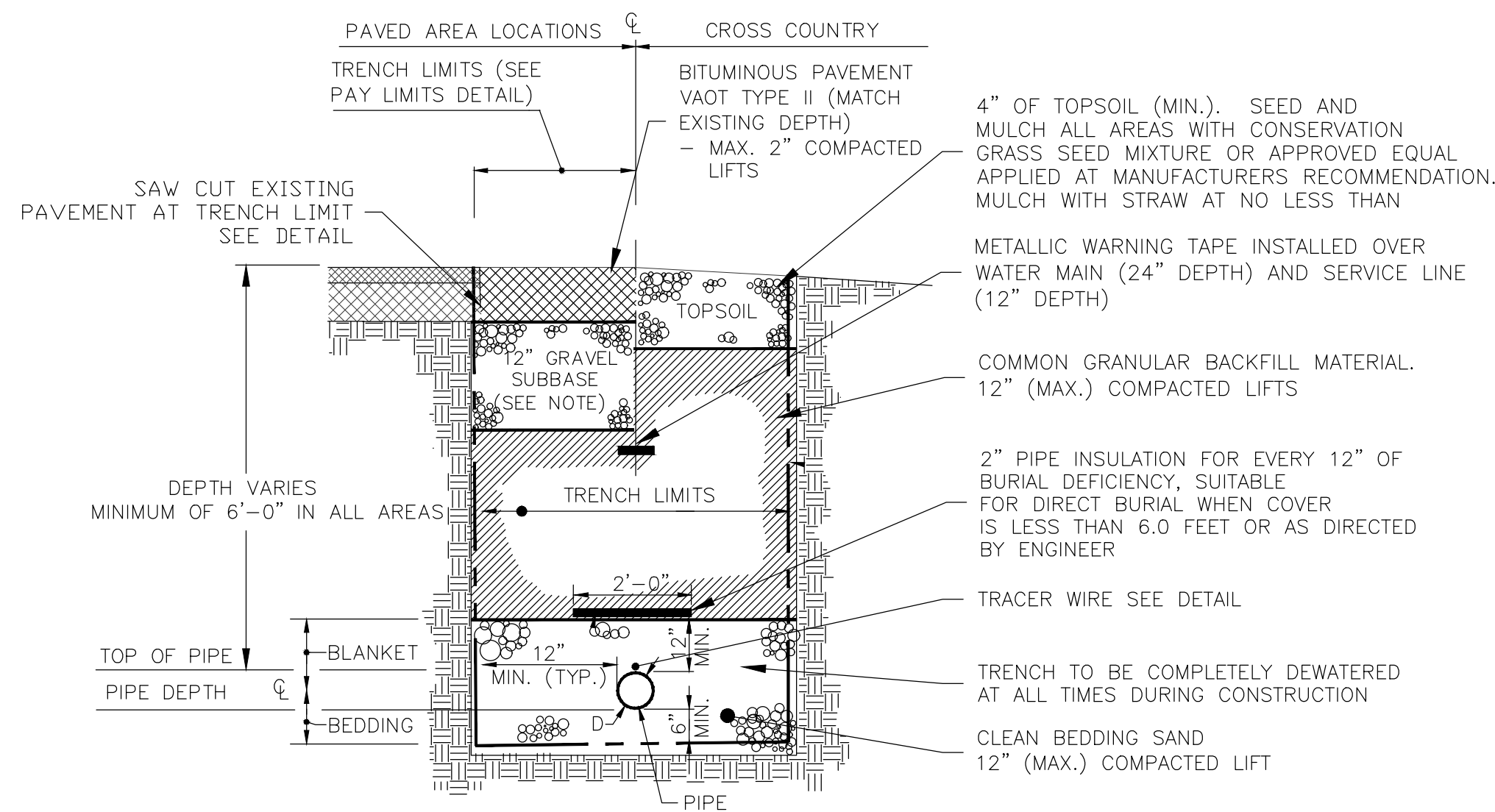

WATER MAIN & SERVICE TRENCH
NOT TO SCALE

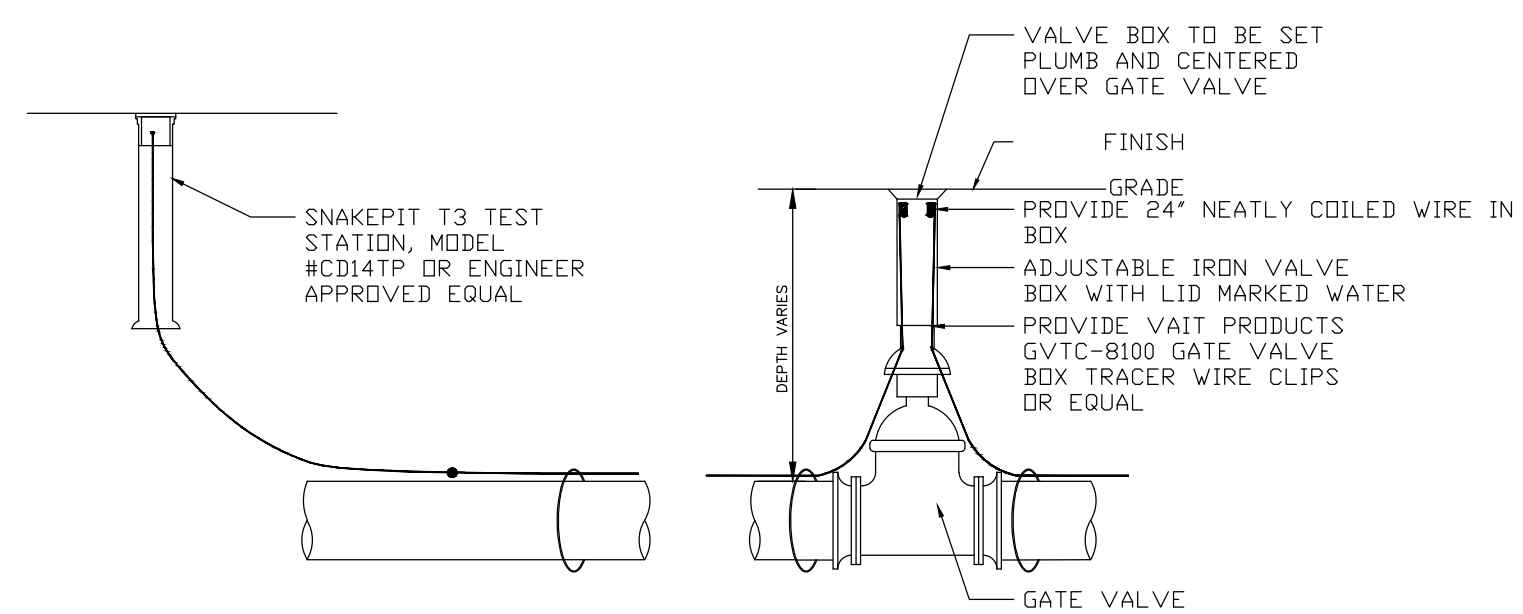

TRACER WIRE FOR WATER MAINS DETAIL
SCALE: NONE

- NOTES
- FOR OPEN CUT INSTALLATION, TRACER WIRE IS TO BE #12 AWG SOLID COPPER WITH 30 MIL BLUE HMWPE INSULATION, 3" WIDE METALLIC WARNING TAPE INSTALLED OVER WATER MAIN (24" DEPTH) AND SERVICE LINE (12" DEPTH) PER TRENCH DETAIL.
 - FOR PVC WATER MAIN PIPE, TRACER WIRE IS TO RUN ALONG TOP OF AND BE SECURED TO WATER MAIN PIPE WITH PLASTIC STRAPS OR TAPE PLACED AT MAXIMUM 8 FEET INTERVALS.
 - AT WATER VALVES TRACER WIRE IS TO RUN ALONG THE SIDE OF THE VALVE OR WHERE SPECIFIED RUN UP BOTH SIDES OF THE VALVE BOX WITH VAIT PRODUCTS GVTC-8100 GATE VALVE BOX TRACER WIRE CLIPS OR APPROVED EQUAL.
 - TRACER WIRE IS TO BE CONNECTED TO TERMINATION BOX INSTALLED ADJACENT TO END POINTS OF NEW PVC WATER MAIN WHERE NECESSARY.

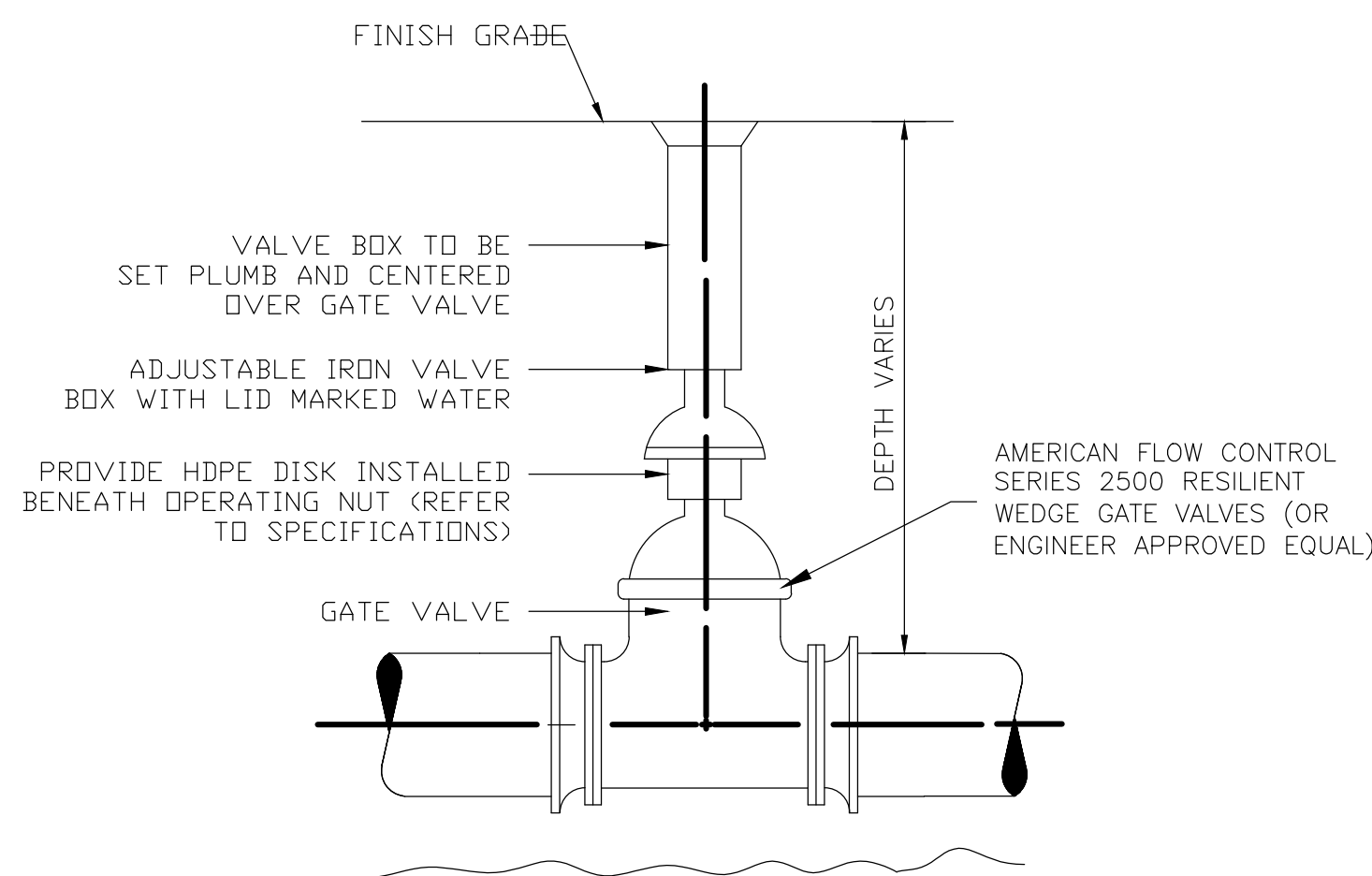

GATE VALVE DETAIL
NOT TO SCALE

NOTES (UNLESS OTHERWISE SPECIFIED ON THESE DRAWINGS):

- COMMON BACKFILL MATERIAL - SHALL BE NATIVE MATERIAL CONTAINING NO CLAY, SILT, OR STONES GREATER THAN SIX INCHES IN DIAMETER, SHALL BE FREE OF ORGANIC MATTER, TOPSOIL, PEAT, MUCK, AND PAVEMENT OR OTHER UNSUITABLE MATERIAL. ALL MATERIAL TO BE PLACED IN 6"-12" LIFTS, DEPENDING ON SURFACE USE. COMPACT BEFORE PLACING NEXT LIFT. UNDER ROADS OR DRIVEWAYS, BACKFILL DESIGNATED "COMPACTED" MEANS 95% MODIFIED PROCTOR. FILL PLACED BELOW AND AROUND PIPES MUST ALSO MEET THESE REQUIREMENT. IN ALL OTHER AREAS, BACKFILL DESIGNATED AS "COMPACTED" MEANS 90% OF MODIFIED PROCTOR. APPROVED EQUAL MATERIAL SHALL BE PLACED IN 6"-12" COMPACTED LIFTS.
- GRAVEL SUBBASE MATERIAL SHALL MEET VAOT 704.05 SPECIFICATIONS OR ENGINEER APPROVED EQUAL. MATERIAL SHALL BE PLACED IN 6"-12" COMPACTED LIFTS.
- BEDDING MATERIAL - BEDDING SHALL PROVIDE FIRM, UNIFORM SUPPORT OVER LENGTH OF PIPE. SHALL BE CLEAN SAND AND MEET PIPE EMBEDMENT SPECIFICATIONS AS NOTED IN CONTRACT SPECIFICATIONS.
- ORDERED EXCAVATION OF UNSUITABLE MATERIAL BELOW GRADE REFILL WITH BEDDING MATERIALS (SEE NOTE 5.)
- SHEETING IF REQUIRED, WHERE SHEETING IS PLACED ALONGSIDE THE PIPE AND EXTENDS BELOW MID-DIAMETER IT SHALL BE CUT OFF AND LEFT IN PLACE TO AN ELEVATION NOT LESS THAN 12" ABOVE THE TOP OF THE PIPE. WHERE THE SHEETING IS ORDERED BY THE ENGINEER TO BE LEFT IN PLACE, IT SHALL BE CUT OFF AT LEAST 5 FEET BELOW FINISH GRADE, BUT NOT LESS THAN 12" ABOVE THE TOP OF THE PIPE.
- CONTRACTOR TO PROVIDE NECESSARY GRADATION TESTS OF ALL MATERIALS BEFORE CONSTRUCTION
- TRENCHES ENTERED BY PERSONNEL OVER 48" IN DEPTH SHALL BE SHEETED OR SLOPED TO THE ANGLE OF REPOSE.
- IF ROADWAY FABRIC IS PRESENT, CUT BACK SUBBASE TO PROVIDE PROPER MANUFACTURERS RECOMMENDED LAP JOINT. FABRIC TO BE MIRAFI 500X OR APPROVED EQUAL.

VTM ENGINEERING, PLC
2941 SHELburnE FALLS ROAD
HINESBURG, VT 05461
(802) 233-7531



WATER LINE DESIGN

PROPOSED WATER DISTRIBUTION SYSTEM SITE PLAN
PLANK ROAD & JAY DRIVE
BRISTOL, VT
HEFFERNAN REVOCABLE TRUST
BRISTOL, VT 05443

VERMONT
DEPARTMENT OF ENVIRONMENTAL CONSERVATION
Drinking Water & Groundwater Protection Division

THIS IS SUBJECT TO PROVISIONS OR CONDITIONS LISTED IN PERMIT
Permit #: **WW-9-1537-4**
Date: **04/25/2024**

DESIGNED	SP	DATE	2/12/2024
DRAWN	PM	SCALE	AS SHOWN
CHECKED	SP	DATE	2/12/2024
PROJECT NO.	24.1		
DRAWING NO.	C2.0		

CONSTRUCTION NOTES

NOTES:

- 1. BURIED UTILITIES
 - A. UNDERGROUND UTILITY LOCATIONS ARE APPROXIMATE ONLY. THOSE SHOWN ON THE DRAWINGS ARE BASED ON THE BEST AVAILABLE INFORMATION. PRIOR TO CONSTRUCTION, THE CONTRACTOR SHALL MEET WITH THE ENGINEER, OWNER, AND REPRESENTATIVES OF THE WATER DEPARTMENT, TELEPHONE COMPANY, ELECTRIC COMPANY, GAS COMPANY, SEWER DEPARTMENT, AND ANY OTHER UTILITIES THAT MAY BE INVOLVED WITH THE CONSTRUCTION PROJECT TO COORDINATE THE MARKING, AND TIMING OF DISRUPTIONS OF VARIOUS UTILITIES. IF ANY, THE CONTRACTOR IS RESPONSIBLE FOR VERIFYING ALL UTILITY LOCATIONS, ELEVATIONS, OR CONFLICTS.
 - B. THE CONTRACTOR IS RESPONSIBLE FOR ALL DAMAGE TO EXISTING UTILITIES AND SHALL BE RESPONSIBLE FOR REPAIR OF ANY SUCH DAMAGE AS QUICKLY AS POSSIBLE AT HIS/HER OWN EXPENSE. THE CONTRACTOR SHALL MAINTAIN A SUPPLY OF REPAIR MATERIALS AND PIPE ON THE JOB SITE AT ALL TIMES IN ORDER TO MINIMIZE THE INCONVENIENCE CAUSED BY SUCH DAMAGE.
 - C. THE CONTRACTOR SHALL PERMANENTLY PLUG ALL EXISTING LINES WHICH ARE REPLACED BY NEW ONES AT THE POINT WHERE THEY ARE DISCONNECTED UNLESS THEY ARE TO REMAIN IN SERVICE.

- 2. WATER UTILITY CONSTRUCTION
 - A. THE CONTRACTOR SHALL USE ONLY DESIGNATED BENCH MARKS FOR REFERENCE ELEVATIONS, WHICH SHALL BE PROVIDED BY THE ENGINEER PRIOR TO CONSTRUCTION.
 - B. MECHANICAL JOINT FITTINGS SHALL BE USED ON ALL PIPE JOINTS WITH PIPE LENGTHS OF LESS THAN 20' AND AS OTHERWISE DETERMINED BY THE ENGINEER. MECHANICAL JOINTS SHALL BE EBAA SERIES 1900 OR ENGINEER APPROVED EQUAL.
 - C. ADDITIONAL FITTINGS & BENDS AS NECESSARY SHALL BE PROVIDED BY THE CONTRACTOR AT NO ADDITIONAL COST IN ORDER TO FURNISH A COMPLETE & FUNCTIONAL SYSTEM.
 - D. EXISTING WATER MAINS ARE UNDER PRESSURE. THE CONTRACTOR IS ADVISED TO TAKE PRECAUTIONS TO AVOID DAMAGE OR "BLOW OUT" OF EXISTING WATER MAINS FROM THE SIDES OF THE TRENCHES DURING CONSTRUCTION. HAND EXCAVATION AS WELL AS TEMPORARY SHEETING AND BRACING MAY BE REQUIRED.
 - E. THE CONTRACTOR SHALL INSTALL A MECHANICAL PLUG IN THE END OF THE PIPE AT THE COMPLETION OF EACH WORK DAY TO SEAL IT FROM WATER AND SOIL.
 - F. ALL BURIED WATER PIPE SHALL BE PVC AWWA C-900 DR-18 PUSH ON TYPE JOINT UNLESS OTHERWISE NOTED. ALL FITTINGS AND APPURTENANCES SHALL BE MECHANICAL JOINT WITH MEGA-LUG OR EQUAL RETAINER GLANDS UNLESS OTHERWISE NOTED, AS PER SPECIFICATIONS.
 - G. THRUST RESTRAINTS SHALL BE PROVIDED FOR ALL WATERLINE TEES & BENDS, AS OUTLINED ON THRUST RESTRAINT DETAILS.
 - H. CONTRACTOR SHALL FULLY STAKE OR INDELIBLY MARK EACH SECTION OF LINE TO BE CONSTRUCTED STAKING SHALL CONSIST OF A WITNESS MARK AT EACH 50' STATION. AT EACH BEND LOCATION, AT EACH ACCESSORY (HYDRANT, AIR RELEASE, GATE VALVE, BLOW OFF, MANHOLE, CATCH BASIN, ETC..) STAKING SHALL BE COMPLETED AT LEAST 1000' AHEAD OF ANY CONSTRUCTION CREW AT ANY TIME AND SHALL BE THE RESPONSIBILITY OF THE CONTRACTOR WITH ASSISTANCE FROM THE ENGINEER AND THE OWNER.
 - I. ASBESTOS-CEMENT (AC) PIPE IS CONSIDERED A HAZARDOUS SUBSTANCE. THE CONTRACTOR IS RESPONSIBLE FOR
 - a.) TAKING THE PROPER PRECAUTIONS ASSOCIATED WITH WORKING WITH AC PIPE.
 - b.) ANY WORK WITH ASBESTOS CEMENT PIPE MUST COMPLY WITH ALL APPLICABLE VRAC, VOSHA, STATE OF VERMONT, AND OSHA REQUIREMENTS
 - c.) PROPER DISPOSAL OF ALL AC PIPE REMOVED FROM THE PROJECT AT NO ADDITIONAL COST TO OWNER

- 3. SITE WORK
 - A. EXISTING FENCES, FLOWERS, BUSHES, TREES, MAILBOXES, SIGNS, CATCH BASINS, CULVERT HEADWALLS, ETC., REMOVED BY THE CONTRACTOR SHALL BE REPLACED TO AT LEAST THEIR ORIGINAL CONDITION. THE CONTRACTOR IS RESPONSIBLE FOR RECORDING PRE-CONSTRUCTION CONDITIONS BY USE OF PHOTOGRAPHS, VIDEO TAPES, AND OTHER METHODS. THE COST OF THIS PRE-CONSTRUCTION DOCUMENTATION SHALL BE CONSIDERED INCIDENTAL TO THE PROJECT.
 - B. SOME MAILBOXES AND SIGNS ARE NOT SHOWN ALONG PROJECT ROUTE FOR REASONS OF CLARITY. THE CONTRACTOR SHALL RESET ALL MAILBOXES AND SIGNS AS SOON AS POSSIBLE.
 - C. THE CONTRACTOR SHALL NOTE SPECIAL CONDITIONS IN THE SPECIFICATIONS REGARDING TREES, PLANTS, SHRUBS, GRASS TREE ROOT FERTILIZATION, TIME LIMITATIONS, AND OTHER RELATED REQUIREMENTS.
 - D. TREES LOCATED WITHIN THE R.O.W OR ANY CONSTRUCTION EASEMENT LIMIT SHALL NOT BE TRIMMED, DAMAGED, OR DESTROYED WITHOUT PERMISSION FROM THE PROPERTY OWNER ON A LOCATION BY LOCATION BASIS.
 - E. THE CONTRACTOR SHALL ENTER INTO ONLY WRITTEN AGREEMENTS AS TO STAGING AREAS AND STORAGE AREAS. A COPY OF THE AGREEMENT SHALL BE PROVIDED TO THE OWNER PRIOR TO THE USE OF THE SITE OR AREA.
 - F. THE CONTRACTOR SHALL BE RESPONSIBLE FOR HOLDING UTILITY POLES AS NECESSARY. COSTS FOR WORKING NEAR AND AROUND UTILITY POLES SHALL BE PART OF THE UNIT PRICE BID FOR STORM DRAINS. CONTRACTOR SHALL COORDINATE ALL UTILITY POLE HOLDING WITH THE POLE OWNER (UTILITY). ALL WORK SHALL BE IN CONFORMANCE WITH THE UTILITY COMPANY REQUIREMENTS.

- 4. RECORD DRAWINGS
 - A. ALL BURIED UTILITIES ENCOUNTERED SHALL BE DOCUMENTED BY SURVEY OR THREE (3) TIES AND SHOWN BY THE CONTRACTOR ON RECORD DRAWINGS.
 - B. ALL NEW VALVES, FITTINGS, CURB STOPS, CORPORATION STOPS, WYES, AND SEWER CONNECTIONS SHALL BE DOCUMENTED WITH THREE (3) TIES AND SHOWN BY THE CONTRACTOR ON THE RECORD DRAWINGS. THESE TIES SHALL IMMEDIATELY BE PROVIDED TO THE ENGINEER.

- 5. SAFETY AND PROTECTION
 - A. THE CONTRACTOR SHALL BE RESPONSIBLE FOR INITIATING, MAINTAINING AND SUPERVISING ALL SAFETY PRECAUTIONS AND PROGRAMS IN CONNECTION WITH THE WORK. CONTRACTOR SHALL TAKE ALL NECESSARY PRECAUTIONS FOR THE SAFETY OF, AND SHALL PROVIDE THE NECESSARY PROTECTION TO PREVENT DAMAGE, INJURY, OR LOSS TO:
 - a.) ALL EMPLOYEES ON THE WORK SITE AND OTHER PERSONS WHO MAY BE AFFECTED THEREBY
 - b.) ALL THE WORK AND ALL MATERIALS OR EQUIPMENT TO BE INCORPORATED THEREIN, WHETHER IN STORAGE ON, OR OFF, THE SITE AND
 - c.) OTHER PROPERTIES AT THE SITE OR ADJACENT THERETO, INCLUDING TREES, SHRUBS, LAWNS, WALKS, PAVEMENTS, ROADWAYS, STRUCTURES, AND UTILITIES NOT DESIGNATED FOR REMOVAL, RELOCATION, OR REPLACEMENT IN THE COURSE OF CONSTRUCTION.
 - B. CONTRACTOR SHALL COMPLY WITH ALL APPLICABLE STANDARDS (SPECIFICALLY INCLUDING OSHA, VOSHA, AND ANY OTHER STATE ADOPTED OSHA PROGRAM), LAWS, ORDINANCES, REGULATIONS AND ORDERS OF ANY PUBLIC BODY HAVING JURISDICTION FOR THE SAFETY OF PERSONS OR PROPERTY OR TO PROTECT THEM FROM DAMAGE, INJURY, OR LOSS, AND SHALL ERECT AND MAINTAIN ALL NECESSARY SAFEGUARDS FOR SUCH SAFETY AND PROTECTION. CONTRACTOR SHALL NOTIFY OWNERS OF ADJACENT PROPERTY AND UTILITIES WHEN EXCAVATION OF THE WORK MAY AFFECT THEM. CONTRACTOR'S DUTIES AND RESPONSIBILITIES FOR THE SAFETY AND PROTECTION OF THE WORK SHALL CONTINUE UNTIL SUCH TIME AS THE WORK IS COMPLETED AND ACCEPTED BY THE OWNER.
 - C. THE CONTRACTOR SHALL CONTACT "DIGSAFE" AT 1-888-344-7233 PRIOR TO EXCAVATING IN CONSTRUCTION AREAS IN ORDER TO LOCATE BURIED UTILITIES.

- 6. EROSION CONTROL & CONSTRUCTION SEQUENCE
 - A. EROSION CONTROL SHALL BE PROVIDED AS NECESSARY BY THE CONTRACTOR. EROSION CONTROL MEASURES SHALL BE IN ACCORDANCE WITH THE VERMONT STATE STANDARDS AND SPECIFICATIONS LISTED BELOW. PREVENTATIVE EROSION CONTROL AND MEASURES SHALL BE IN PLACE PRIOR TO CONSTRUCTION AND ALL DISTURBED AREAS ARE TO BE IMMEDIATELY STABILIZED.
 - B. SILT FENCE AND SNOW FENCE SHALL BE INSTALLED PRIOR TO BEGINNING CONSTRUCTION. THESE AREAS ARE CONSIDERED TO HAVE THE HIGHEST POTENTIAL FOR EROSION DUE TO THE PROXIMITY TO WETLANDS OR STREAMS. RESTORATIONS (TOPSOIL, MATTING, RAKING, SEED, FERTILIZER, AND MULCH) MEASURES IN THESE AREAS ARE CRITICAL AND SHALL BE COMPLETED WITHIN 48 HOURS OF FINAL GRADING. IN NO CASE SHALL WORK BE DONE IN THESE AREAS BETWEEN OCTOBER 15TH AND MAY 1ST.
 - C. CONSTRUCTION SHALL PROCEED AREA BY AREA TO FACILITATE INSTALLATION OF EROSION CONTROL MEASURES AND COMPLETION OF GRADING, SEEDING AND MULCHING. THIS PROCEDURE IS INTENDED TO EXPOSE THE SMALLEST PRACTICAL LAND AREA AT ANY ONE TIME.
 - D. PARTICULAR ATTENTION SHALL BE GIVEN TO MAINTAINING THE STABILITY OF DOWN GRADIENT AREAS AND RUNOFF CONTROL WHERE POSSIBLE, ALWAYS AVOID CONCENTRATION OF STORM WATER RUNOFF.
 - E. ANY SOILS TEMPORARILY EXPOSED LONGER THAN SEVEN (7) DAYS OR IN ADVANCE OF PREDICTED LARGE STORMS SHALL BE STABILIZED.
 - F. ALL EXISTING INLETS AND INLETS INSTALLED DURING CONSTRUCTION SHALL BE PROTECTED FROM EROSION VIA A "DROP-IN" FILTER BAG PRODUCT (ADS FLEXSTORM OR EQUAL) AND SHALL BE REGULARLY MONITORED AND MAINTAINED/REPLACED THROUGHOUT CONSTRUCTION TO INSURE PROPER PERFORMANCE.
 - G. UPON COMPLETION OF CONSTRUCTION AND ONCE ALL PERMANENT VEGETATIVE COVER IS FIRMLY ESTABLISHED, ALL TEMPORARY EROSION CONTROL DEVICES SHALL BE REMOVED.
 - H. CONSTRUCTION SHALL BE CONDUCTED IN ACCORDANCE WITH THE VERMONT EROSION PREVENTION AND SEDIMENT CONTROL FIELD GUIDE AND THE LOW RISK SITE HANDBOOK FOR EROSION CONTROL AND SEDIMENT PREVENTION.
 - I. SEE SPECIFICATIONS FOR MORE INFORMATION.
 - J. REGULARLY SCHEDULED COMMERCIAL SWEEPING OF THE ENTIRE PROJECT AREA SHALL BE CONDUCTED (NOT TO EXCEED WEEKLY) AND MORE FREQUENTLY IF NECESSARY.

- 7. EASEMENTS
 - A. CONTRACTOR SHALL PERFORM ALL WORK WITHIN EASEMENT LIMITS AND/OR RIGHTS-OF-WAY AS SHOWN ON THE PLANS EXCEPT WHERE TEMPORARY CONSTRUCTION EASEMENTS AND OTHER LEGAL AGREEMENTS ALLOW.
 - B. TOPOGRAPHICAL SURVEY OBTAINED FROM LAROSE SURVEYS, PC, PROPERTY LINES, RIGHTS-OF-WAY, AND EASEMENT LIMITS ARE SHOWN FOR CONSTRUCTION PURPOSES AND ARE NOT TO BE CONSTRUED AS BOUNDARY SURVEY INFORMATION. THIS IS NOT A BOUNDARY SURVEY AND VTM ENGINEERING IS NOT RESPONSIBLE FOR THE ACCURACY OF INFORMATION PROVIDED BY OTHERS. RIGHTS-OF-WAY, PROPERTY LINES, AND EASEMENT BOUNDARIES ARE APPROXIMATE ONLY.

- 1. TOPOGRAPHIC AND EXISTING FEATURES INFORMATION OBTAINED FROM DIGITAL INFORMATION PROVIDED BY LAROSE SURVEYS, PC. THE VERTICAL DATUM IS NAD87. THE HORIZONTAL DATUM IS NAD83
- 2. UNDERGROUND UTILITY LOCATIONS ARE APPROXIMATE ONLY. THOSE SHOWN ON THE DRAWINGS ARE BASED ON THE BEST AVAILABLE INFORMATION. PRIOR TO CONSTRUCTION, THE CONTRACTOR SHALL MEET WITH THE ENGINEER, OWNER AND REPRESENTATIVES OF THE WATER DEPARTMENT, TELEPHONE COMPANY, ELECTRIC COMPANY, GAS COMPANY, SEWER DEPARTMENT, AND ANY OTHER UTILITIES THAT MAY BE INVOLVED WITH THE CONSTRUCTION PROJECT TO COORDINATE THE MARKING, AND TIMING OF DISRUPTIONS OF VARIOUS UTILITIES. IF ANY, THE CONTRACTOR IS RESPONSIBLE FOR VERIFYING UTILITY LOCATIONS AND ELEVATIONS.
- 3. CONTRACTOR TO PROVIDE PROPOSED SEQUENCE OF CONSTRUCTION WITHIN 10 DAYS OF PROJECT AWARD.
- 4. ALL EXISTING WSO'S (CURB STOPS) AND GATE VALVES SHALL BE TURNED OFF AND CURB BOXES / VALVE BOXES REMOVED UPON CONSTRUCTION COMPLETION. FILL AND REPAIR ALL CAVITIES LEFT AFTER BOX REMOVAL. CURB STOPS SHALL ALSO HAVE RODS REMOVED OR CUT @ VALVE PRIOR TO ABANDONMENT.
- 5. ALL WATER MAIN CURVES / DEFLECTIONS SHALL BE MIN. 500' RADIUS (12" WATER MAIN) OR PER MANUFACTURERS RECOMMENDATIONS.
- 6. MAINTAIN 10' HORIZONTAL CLEARANCE BETWEEN SANITARY SEWER AND POTABLE WATER PIPES ON PARALLEL RUNS. MAINTAIN 18" MINIMUM VERTICAL CLEARANCE BETWEEN ALL SANITARY SEWER AND POTABLE WATER PIPES AT CROSSINGS - SEE CROSSING DETAIL.
- 7. CONTRACTOR TO PROVIDE, INSTALL, AND MAINTAIN STORMWATER INLET FILTER UNITS ON ALL INLETS THROUGHOUT PROJECT WHERE APPLICABLE. FILTER UNITS TO BE INSTALLED ON EXISTING INLETS PRIOR TO DISTURBANCE AND AT TIME OF INSTALLATION. INLET FILTER TO BE ADS FLEXSTORM, OR EQUAL - SEE SPECIFICATIONS.
- 8. ALL EXISTING PIPES TO BE DECOMMISSIONED AND ABANDONED WHICH ARE LEFT IN PLACE SHALL BE CAPPED / PLUGGED.
- 9. PRESSURIZED NATURAL GAS MAINS EXIST WITHIN THE PROJECT EXTENTS. CLOSE COORDINATION WITH NATURAL GAS PROVIDER IS REQUIRED TO PREVENT ACCIDENTAL IMPACTS.
- 10. CONTRACTOR SHALL MAINTAIN ONE WAY TRAFFIC AT ALL TIMES DURING CONSTRUCTION.
- 11. SEE DETAILS AND SPECIFICATIONS FOR MORE INFORMATION.

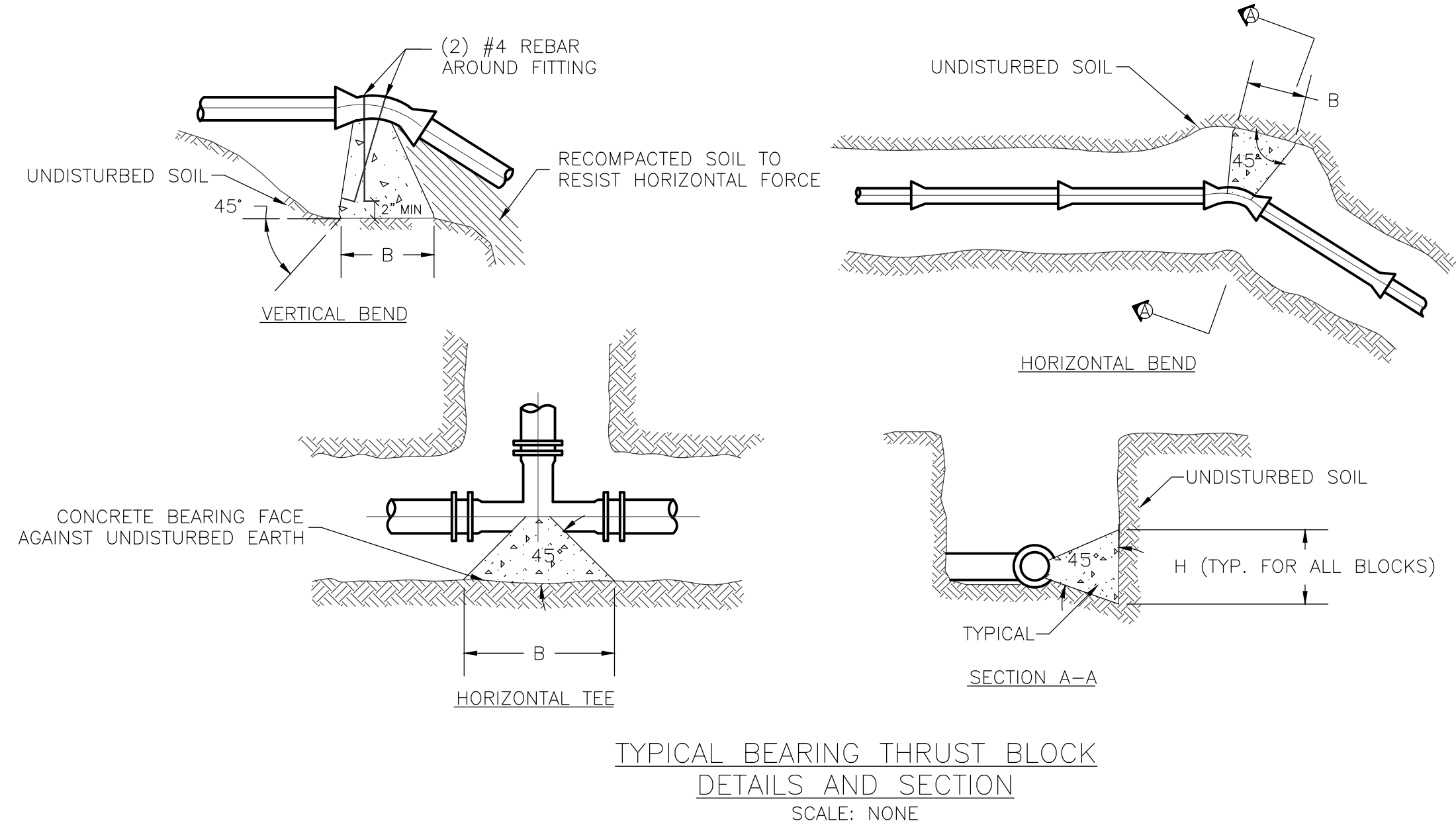

- NOTES:
 - 1. ALL THRUST BLOCKS SHALL BE CLASS "B" CONCRETE, SEE SPEC. SECTION 03300
 - 2. CONCRETE SHALL BE PLACED SO AS NOT TO HAMPER THE FUTURE REMOVAL OF A FITTING.
 - 3. WRAP FITTINGS IN (2) LAYERS POLYETHYLENE PLASTIC SHEET PRIOR TO FORMING AND POURING THRUST BLOCK.

MINIMUM BEARING FACE "HEIGHTS AND WIDTHS" FOR CONCRETE THRUST BLOCKS (TEST PRESSURE = 250 PSI)

BEARING FACE MATERIALS 2	PIPELINE SIZE	HEIGHT (H) AND WIDTH (B) OF BEARING FACE FOR FITTING TO BE RESTRAINED 3											
		11-1/4" BEND		22-1/2" BEND		45° BEND		90° BEND		TEES & PLUGS		WYES	
		H	B	H	B	H	B	H	B	H	B	H	B
WELL GRADED SANDS AND GRAVEL	4" & 6"	1.30	1.30	1.30	1.30	1.30	1.95	1.65	2.60	1.30	2.30	1.30	1.95
	8"	1.30	1.30	1.30	1.30	1.65	2.60	1.95	3.55	1.95	2.60	1.65	2.60
	10"	1.30	1.30	1.65	1.95	1.95	3.25	2.60	4.20	2.60	2.90	1.95	3.25
	12"	1.30	1.95	1.65	2.60	2.60	3.25	2.90	5.20	2.90	3.90	2.60	3.25
SILT	4" & 6"	1.30	1.30	1.30	1.30	1.30	2.30	1.65	3.25	1.95	1.95	1.30	2.30
	8"	1.30	1.30	1.30	1.95	1.95	2.60	2.30	4.20	2.30	2.90	1.95	2.60
	10"	1.30	1.65	1.65	2.60	2.30	3.55	3.25	4.55	2.30	4.55	2.30	3.55
	12"	1.30	2.30	2.30	2.60	2.30	5.20	3.25	6.45	3.25	4.55	2.30	5.20
COHESIVE GRANULAR	4" & 6"	1.30	1.30	1.30	1.30	1.30	2.60	1.95	3.25	1.95	2.30	1.30	2.60
	8"	1.30	1.30	1.30	2.30	1.95	2.90	2.60	4.20	1.95	3.90	1.95	2.90
	10"	1.30	1.95	1.65	2.90	2.60	3.55	3.25	5.20	2.60	4.55	2.60	3.55
	12"	1.30	2.60	2.30	2.90	2.60	5.20	3.90	6.15	3.25	5.20	2.60	5.20
CLAY	4" & 6"	1.30	1.30	1.30	1.30	1.30	2.60	2.30	2.60	1.65	2.60	1.30	2.60
	8"	1.30	1.30	1.30	2.30	1.95	2.90	2.30	4.55	1.95	3.90	1.95	2.90
	10"	1.30	1.95	1.60	2.90	2.30	3.90	2.90	5.50	2.90	3.90	2.30	3.90
	12"	1.30	2.60	1.95	3.25	2.60	4.85	3.55	6.45	2.90	5.50	2.60	4.85

- 1. HYDROSTATIC AND LEAKAGE TEST PRESSURE PER SPECIFICATIONS.
- 2. UNDISTURBED EARTH: SIDE OF TRENCH OR OTHER EXCAVATION.
- 3. SEE DIAGRAM FOR H AND B LOCATION REFERENCE. MEASURED IN FEET.
- NOTE: CONTRACTOR MAY SUBMIT OPTIONAL THRUST RESTRAINT DEVICES, SUCH AS "GRIPPER RINGS" OR RETAINER GLANDS, FOR REVIEW BY ENGINEER IN LIEU OF, OR IN ADDITION TO, THE THRUST BLOCK DETAILS SHOWN ABOVE.

NOTES:

THE #2 HYDRANT INLET SHALL BE: _____ OUTLET SHALL BE: _____

#2 ECLIPSE POST HYDRANT TO BE INSTALLED AT THE FOLLOWING LOCATIONS: _____

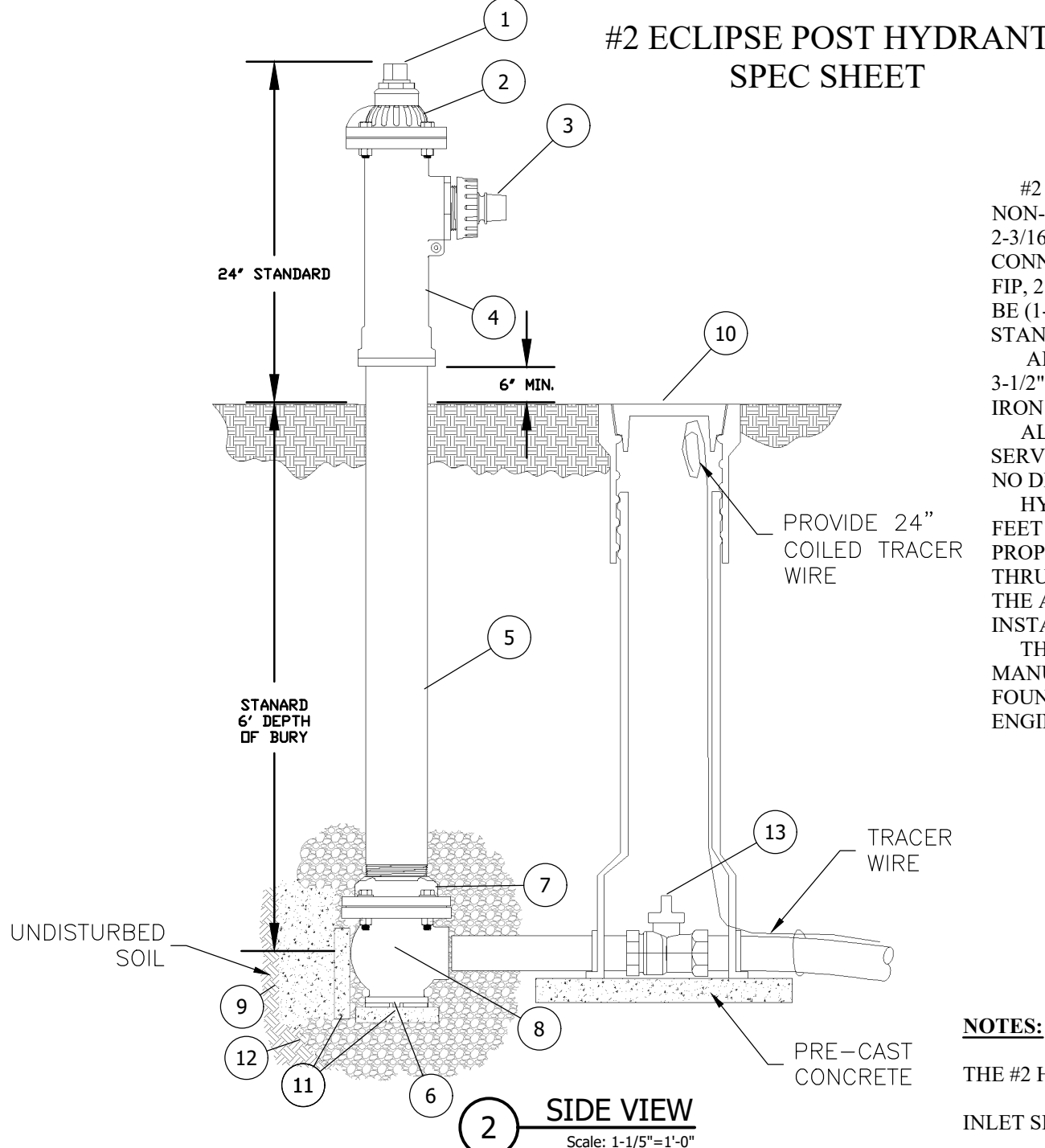

ITEM	ITEM / DESCRIPTION	NOTES
1	OPERATING SCREW	
2	TIP CAP	
3	SIDE CAP	
4	TOP STOCK	
5	3-1/2" FBE COATED STEEL PIPE	
6	DRAIN HOLE LEAVE PLUGGED	
7	COUPLING	
8	INLET VALVE BODY	
9	UNDISTURBED EARTH	BY OTHERS
10	VALVE BOX	BY OTHERS
11	THRUST BLOCKS	BY OTHERS
12	CRUSHED ROCK	BY OTHERS
13	HYDRANT SHUT-OFF VALVE	BY OTHERS

2511 NORTH 9TH STREET
ST. LOUIS, MO 63102
1-800-231-3990
FAX 314-231-2820
www.hydrants.com

KUPFERLE Since 1887

SCALE: 1-1/8"=1'-0"

SHEET 1 OF 1

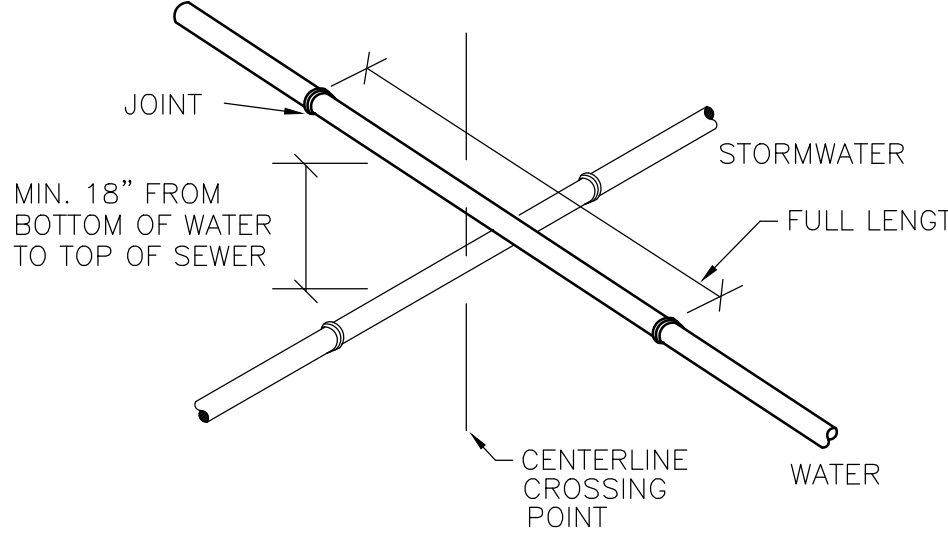

- NOTES:
 - 1. NEW WATER MAINS SHALL BE LAID AT LEAST 10' FROM EXISTING SEWER LINES WHEN RUNNING PARALLEL AND AT SAME ELEVATION.
 - 2. WHERE A NEW WATER MAIN CROSSES OVER AN EXISTING SEWER LINE THERE WILL BE A MINIMUM VERTICAL SEPARATION DISTANCE OF 18" BETWEEN THE OUTSIDE OF THE WATER AND THE OUTSIDE OF THE SEWER. AT CROSSINGS, ONE FULL LENGTH OF WATER PIPE SHALL BE LOCATED SO AS BOTH JOINTS ARE AS FAR FROM THE SEWER AS POSSIBLE.
 - WHERE A NEW WATER MAIN CROSSES UNDER AN EXISTING SEWER LINE THERE WILL BE A MINIMUM VERTICAL SEPARATION DISTANCE OF 18" BETWEEN THE OUTSIDE OF THE WATER AND THE OUTSIDE OF THE SEWER. AT CROSSINGS, ONE FULL LENGTH OF WATER PIPE SHALL BE LOCATED SO AS BOTH JOINTS ARE AS FAR FROM THE SEWER AS POSSIBLE. BOTH JOINTS OF THE CROSSING WATER LINE SECTION SHALL BE CONCRETE ENCASED AND THE SEWER PROPERLY SUPPORTED.

VERMONT DEPARTMENT OF ENVIRONMENTAL CONSERVATION
Drinking Water & Groundwater Protection Division
THIS IS SUBJECT TO PROVISIONS OR CONDITIONS LISTED IN PERMIT
Permit #: WW-9-1537-4
Date: 04/25/2024

WATER/STORMWATER SEPARATION DETAIL SCALE: NONE

VTM ENGINEERING, PLC
2941 SHELburnE FALLS ROAD
HINESBURG, VT 05461
(802) 233-7531



WATER LINE DESIGN

PROPOSED WATER DISTRIBUTION SYSTEM SITE PLAN
PLANK ROAD & JAY DRIVE BRISTOL, VT
HEFFERNAN REVOCABLE TRUST BRISTOL VT 05443

DESIGNED	SP	SCALE	DATE
DRAWN	PM	AS SHOWN	
CHECKED	SP	DATE	2/12/2024

PROJECT NO. 24.1
DRAWING NO. C2.1